

Moderate Overlap Frontal Crashworthiness Evaluation 2.0 Crash Test Protocol

Version I

June 2023



Insurance Institute for Highway Safety

988 Dairy Road

Ruckersville, VA 22968

researchpapers@iihs.org

+1 434 985 4600

iihs.org



CONTENTS

OVERVIEW	3
Test vehicle selection	3
TEST CONDITIONS	3
Impact speed and overlap	3
Barrier composition and preparation.....	4
Test vehicle preparation	5
Crash dummy preparation and setup.....	9
Photography.....	10
MEASUREMENTS AND OBSERVATIONS	14
Test weight	14
Impact speed.....	14
Overlap.....	14
Fuel system integrity.....	14
High-voltage system integrity	15
Intrusion measurements	15
SENSOR DATA COLLECTION	17
Vehicle accelerations	17
Seat belt load cells	17
Pressure mat sensor.....	17
Dummy responses.....	18
REFERENCES.....	22
APPENDIX: INSTALLING THE PRESSURE SENSOR	23
Step 1: Establishing the dummy thorax coordinate system.....	23
Step 2: Installing the chest jacket and pressure sensor on the dummy.....	26

OVERVIEW

Testing procedures outlined in this document are largely similar to those in the previous moderate overlap testing protocol, *Moderate Overlap Crash Test protocol (Version XIX)*, with the addition of a 5th percentile female Hybrid III dummy in the left rear-seating position.

Supporting documents for the Insurance Institute for Highway Safety (IIHS) frontal offset crash test program are available from the Technical Protocols section of the IIHS website.

Test vehicle selection

For information on how we select vehicles for our crash test programs, see *Test Vehicle Selection* (IIHS, 2021).

TEST CONDITIONS

Impact speed and overlap

Offset barrier crash tests are conducted at 64.4 ± 1 km/h and a $40 \pm 1\%$ overlap.

The test vehicle is aligned with the deformable barrier such that the right edge of the barrier face is offset to the left of the vehicle centerline by $10 \pm 1\%$ of the vehicle's width (Figure 1).

The vehicle width is defined and measured as indicated in the Society of Automotive Engineers (SAE, 2009) Surface Vehicle Recommended Practice J1100, which states, "The maximum dimension measured between the widest part on the vehicle, excluding exterior mirrors, flexible mud flaps, and marker lamps, but including bumpers, moldings, sheet metal protrusions, or dual wheels, if standard equipment."

Figure 1
Vehicle overlap with deformable barrier

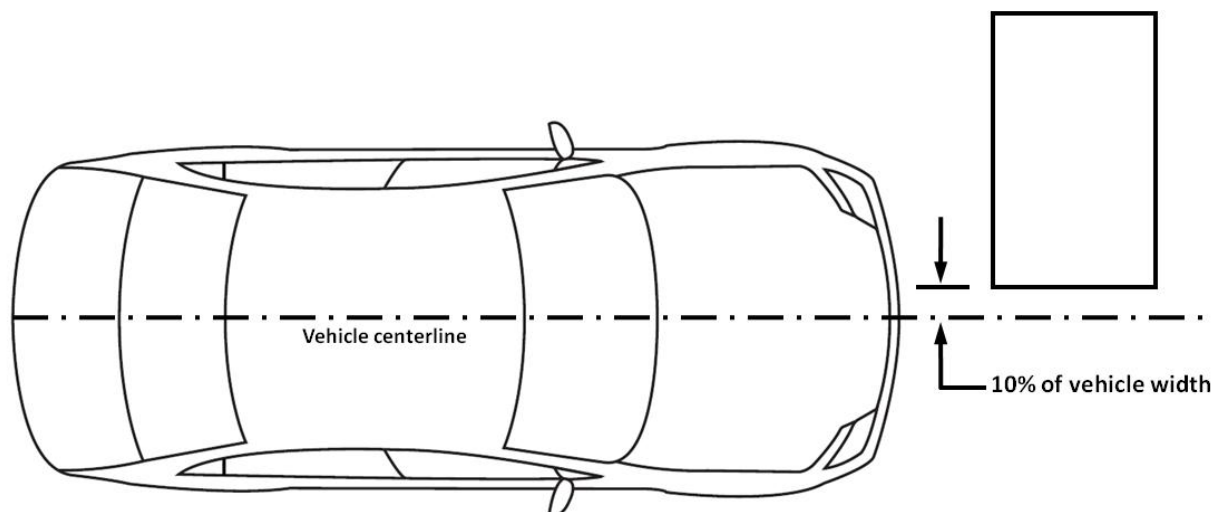

The vehicle is accelerated by the propulsion system at an average of 0.3 g until it reaches the test speed and then is released from the propulsion system 25 cm before the barrier. The onboard braking system, which applies the vehicle's service brakes on all four wheels, is activated 1.0 second after the vehicle is released from the propulsion system.

Barrier composition and preparation

The barrier is composed of three elements: base unit, extension, and deformable face (Figure 2).

The base unit is 184 cm high, 366 cm wide, and 542 cm deep. It is composed of laminated steel and reinforced concrete with a total mass of 145,150 kg.

The extension is 91 cm high, 183 cm wide, and 125 cm deep. It is made of structural steel and has a 1.9-cm thick piece of plywood attached to the 4.5-cm thick face plate.

The deformable face is 1-m wide and consists of a bumper element of 1.723 MPa honeycomb material attached to a base of 0.345 MPa honeycomb material. The face is attached to the extension at a height of 20 cm from the ground. The profile (height and depth) of the deformable face is shown in Figure 3.

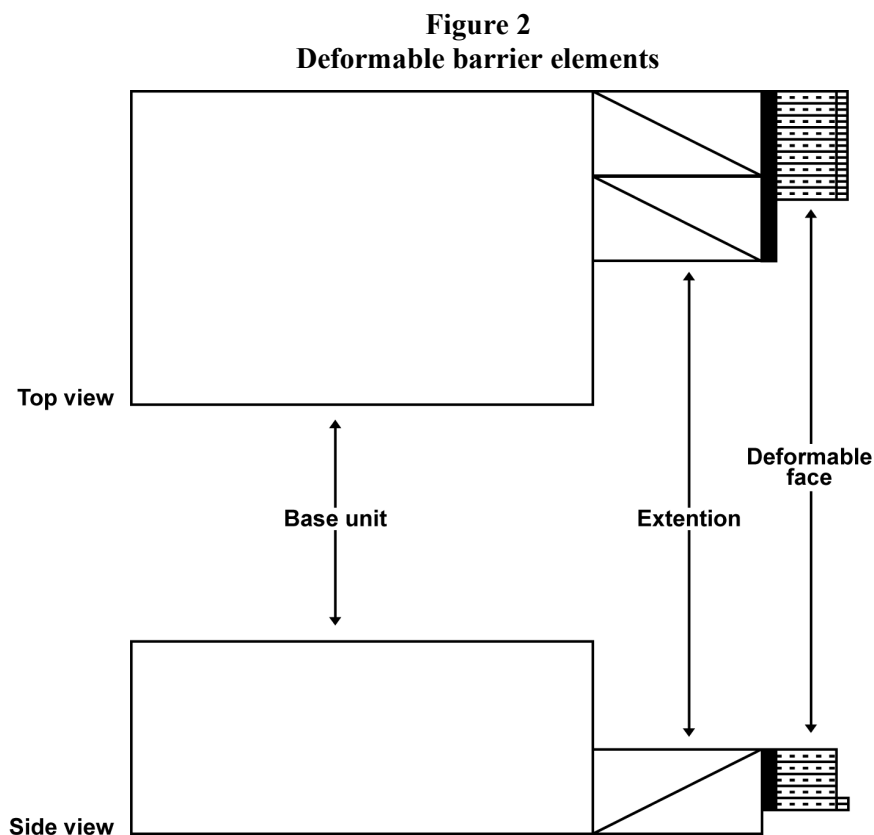
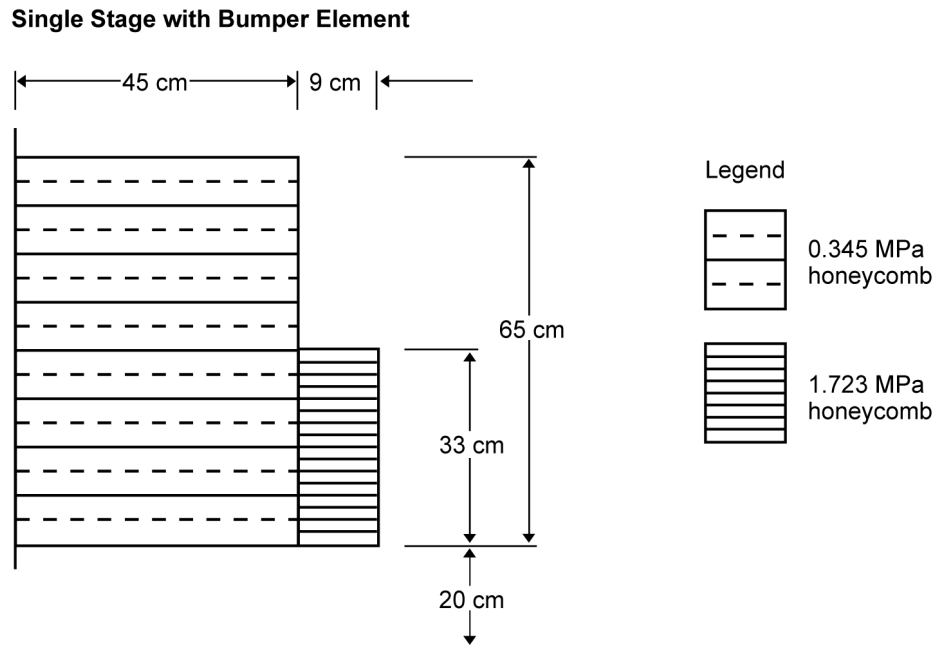

Figure 3
Deformable barrier face profile and dimensions



Segmented tape is applied to the right and leading edges of the top surface of both the bumper element and base to highlight them for the overhead camera views. In addition, both barrier surfaces are marked with a 75-cm length gage consisting of two circular photographic targets (yellow and black reference points).

Test vehicle preparation

Each vehicle is inspected upon arrival at the research center. Vehicles are checked for evidence of prior collision damage or repair. Each vehicle is further examined to verify that it is in satisfactory operating condition and to note defects such as missing parts, maladjustment, or fluid leaks. If directly relevant to testing, such deficiencies are corrected, or a replacement vehicle is procured.

All engine and transmission fluids are drained from the vehicle prior to the test. The gasoline is removed from the fuel tank and fuel lines and replaced with Stoddard solvent to 90%–95% of usable capacity. Purple dye is added to the Stoddard to better identify leaks post-test. The engine is started for short period to ensure that the Stoddard solvent has filled the fuel lines. The electrolyte is drained from the battery. The air conditioning system’s refrigerant is recovered by a means that complies with applicable environmental regulations.

High-voltage batteries in vehicles with full-electric drivetrains are tested at a state of charge (SoC) of 12.5 ± 2.5%, with a minimum of 25 miles of travel capacity on the battery. To avoid the possibility of the hybrid system attempting to begin a charge cycle, (i.e., engine start), the high-voltage batteries in hybrid vehicles are tested at the minimum SoC recommended by the manufacturer. Maintenance fuses are not removed, but additional precrash and postcrash precautions specified by the vehicle manufacturer are followed. Equipment will be added to the high-voltage system in accordance with manufacturer-recommended procedures for monitoring electrical isolation as per Federal Motor Vehicle Safety

Standard (FMVSS) 305. Thermocouple(s) also are attached to the high-voltage battery to detect temperature increases that may indicate a thermal runaway condition.

Four onboard video cameras are placed in the vehicle: one is attached to the right front-passenger door, aft of the A-pillar; one is attached to the rear-passenger door; and two are attached to the roof, facing the rear occupant. Lights for these cameras also are attached to the vehicle. The total weight of the four digital cameras, mounting hardware, camera router, cables, and lights is approximately 26 kg.

The front of the vehicle is attached to the propulsion system via two separate straps, chains, or cables that are wrapped around the left and right sides of the suspension, subframe, or engine cradle. These separate straps, chains, or cables allow components to break away from the vehicle if designed to do so. The rear of the vehicle is attached to the propulsion system with a nylon strap and ratchet strap assembly. The front and rear attachment hardware weighs 10 kg.

Vehicle crash avoidance features are disabled prior to testing by deactivating the system through onboard vehicle settings and/or physically disconnecting the sensors (cameras, radars, etc.).

An aluminum instrumentation rack, which supports the test equipment, is installed in the cargo area of the vehicle. The carpeting in this area is removed to allow access to the floor. If necessary, the spare tire and accessory jack may be removed to permit installation of the instrumentation rack. The following test equipment is installed on the instrumentation rack located in the cargo area:

Onboard emergency braking system: When activated, this system applies pressurized nitrogen gas against the brake fluid in the lines to the rear wheels. The remaining brake fluid in the master cylinder is removed. Flexible hoses connect the emergency braking system to the brake lines in the engine compartment or beneath the vehicle. The onboard braking system weighs approximately 11 kg.

12-volt battery and monitoring system: This system supplies electrical power for the vehicle, emergency braking system, Diversified Technical Systems (DTS) data acquisition system (DAS), and wireless bridge for DAS communication. The system weighs approximately 25 kg. The wireless device for DAS-to-network communication is mounted to the outside of the vehicle and weighs 2 kg.

High-speed camera and onboard lighting power supply: This system supplies electrical power to the onboard high-speed video cameras and LED lighting. The weight of the camera/lighting system is 37 kg.

On-board data acquisition systems: These systems collect and store data from the dummy and vehicle sensors. The combined weight of these systems is 16 kg.

The test weight of the vehicle is 175–225 kg greater than the measured curb weight (weight of the vehicle as delivered from the dealer with full fluid and fuel levels) of the vehicle. If the vehicle test weight needs to be increased to fall within the range, steel plates are added to the instrumentation rack. If the vehicle test weight needs to be decreased, nonessential, nonstructural items are removed from the vehicle.

A steel plate is attached to the floor of the rear-seating area along the centerline of the vehicle for mounting accelerometers. The carpeting in this area is removed to allow access to the floor. If floor mats are standard or offered as an option through the manufacturer or dealership, they are installed in the driver footwell and in the left rear-occupant position.

Daytime-running lights (if equipped) are disabled by means of removing fuses or relays to these devices to reduce the electrical power required for the test.

A plastic block containing an array of high-intensity LEDs is attached to the hood of the vehicle with sheet metal screws. An additional LED is placed inside the vehicle in view of the onboard high-speed cameras. The LEDs are illuminated when the vehicle first contacts the barrier. Two pressure-sensitive tape switches are applied to the vehicle such that they make first contact with the barrier during the crash. Pressure applied to these switches completes an electrical circuit that illuminates the LEDs and signals the start of the crash (time-zero) for the onboard cameras and data acquisition system.

The exterior surfaces of the vehicle are trimmed with segmented tape and photographic targets to facilitate analysis of the high-speed camera footage (Figure 4). The scheme consists of four gages in separate reference planes: three 75-cm length gages, one each on the surface of the roof, on the surface of the driver door, and in a vertical plane passing through the centerline of the driver seat; and one 50-cm length gage on the surface of the hood. The location of the vehicle accelerometers and the location of the vehicle's precrash center of gravity are marked with photographic targets applied to the appropriate top surfaces of the vehicle. An additional target also is placed at the rear of the vehicle on the centerline.

The locations of the driver-door latch, left rear-door latch, and driver shoulder belt upper anchorage D-ring are marked on the side surfaces with photographic targets. The steering wheel is highlighted with tape, and the left front tire is highlighted with white paint. To determine vehicle alignment with the barrier at impact, tape is placed at 39% and 41% of the vehicle width.

Figure 4
Exterior surface Marking

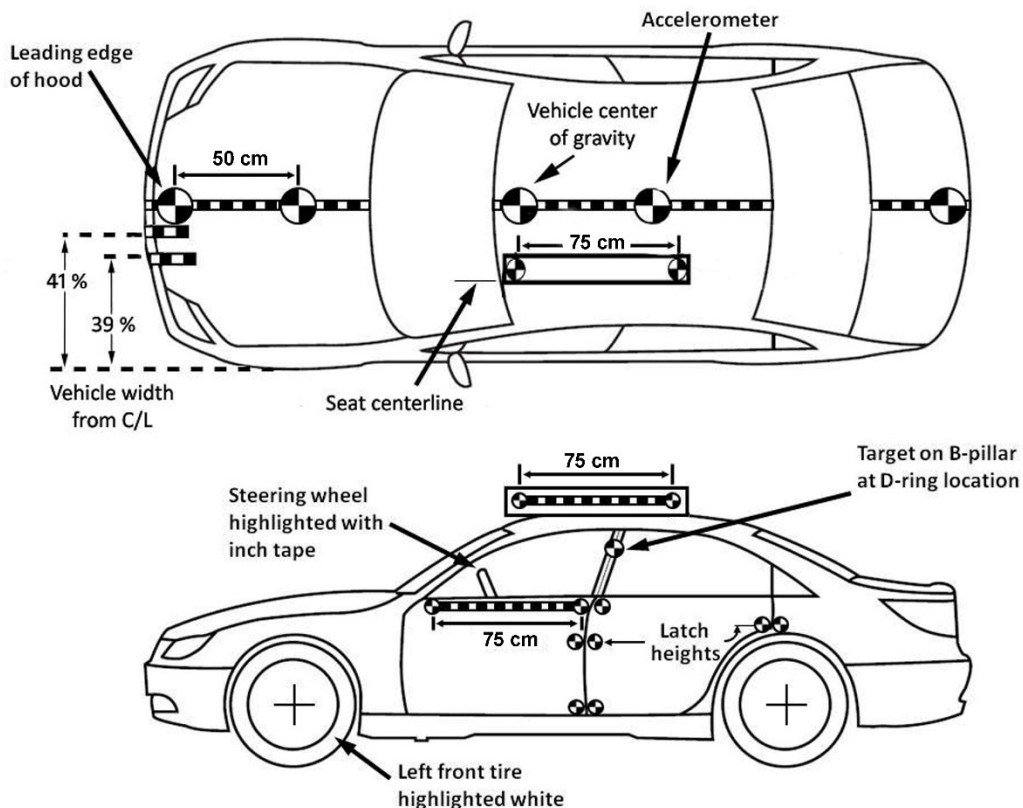

The interior surfaces of the vehicle are also trimmed with tape and photographic targets to facilitate analysis of the high-speed digital video (Figure 5).

The interior of the left rear door, adjacent to the rear-seated occupant, is trimmed with a horizontal tape line, leveled in the vehicle coordinate system Z-axis and low enough to limit its view being obstructed by the side curtain airbag. Two additional target stickers are placed on the tape line a known distance apart so that they are visible in camera K (Table 2) and not obstructed by the dummy prior to the crash. Two vertical excursion measurement lines are also placed on the interior of the left door, with the leading edge of the tapes aligned with the rearmost point on the front seatback in the final test position and 50 mm behind the front seatback line, respectively.

Figure 5
Interior surface marking



The driver's head restraint (if adjustable) is adjusted upward until the top of the head restraint is level with the top of the dummy's head. In cases where the left rear head restraint can be lowered for stowage or positioned for non-use, it shall be set to an in-use position and (if adjustable) adjusted upward until the top of the head restraint is level with the top of the dummy's head. If a head restraint lacks sufficient height adjustment to reach the top of the dummy's head, the test is conducted with the head restraint set at its highest setting. The locking mechanism for adjusting the head restraint height (if equipped) is examined to ensure the mechanism has engaged. All manually adjustable, head-restraint-tilting mechanisms are adjusted to their full-rearward position.

The manually adjustable inboard armrest for the driver seat (if equipped) is adjusted to its lowered position. For vehicles equipped with multiple locking armrest positions, the position that results in the top surface of the armrest being closest to parallel with the ground is chosen. Armrests on the inboard or outboard side of the left rear occupant should either be secured in the stowed (up) position or removed to prevent obscuring the view of the lap belt engagement with the dummy's pelvis.

All doors are fully latched but not locked. However, if the vehicle is equipped with automatic-locking doors that cannot be set to remain unlocked when the vehicle is in forward motion, the door locks are kept in their automatic state. All side windows are lowered to their lowest positions, the ignition is turned to its on position, and the transmission is shifted into its neutral position prior to the test.

Crash dummy preparation and setup

A 50th percentile male Hybrid III dummy (49 *CFR* 572 [E]) (H350M) with instrumented lower legs is positioned in the driver seat according to the *Guidelines for Using the UMTRI ATD Positioning Procedure for ATD and Seat Positioning (Version VI)* (IIHS, 2022b).

A 5th percentile adult female Hybrid III dummy (49 *CFR* 572 (O)) (H35F) is positioned in the second - row left-seating position according to the *Dummy Seating Procedure for Rear Outboard Positions (Version II)* (IIHS, 2022a).

The H350M dummy is equipped with feet and ankles described in the final rule incorporating Hybrid III dummy modifications (Docket 74-14 Notice 104; *FR* vol. 61, no. 249, pp. 67953–67962). The feet have been further modified to include two accelerometers, and the ankles have been modified to prevent metal-to-metal contact that results from bottoming of the ankle bumper (Humanetics Innovative Solutions, Inc., part numbers 78051-653-H and 78051-654-H). The H350M dummy's knees are equipped with ball-bearing sliders, and the neck is fitted with a neck shield.

The H35F dummy is equipped with the harmonized chest jacket described in SAE J2921, and the neck is fitted with a neck shield (SAE, 2013). To enhance visibility of the lap belt interaction with the dummy's abdomen, the H35F dummy is clothed in a form-fitting cotton-stretch above-the-knee pant and wears a pressure mat (XSensor HX210:36.48.05M-HSS incorporated into a vest fitted for the H35F or equivalent) as a shirt.

The dummies used in these tests are recertified according to 49 *CFR* 572 (E) and (O), respectively, after being subjected to no more than five crash tests. Additionally, individual parts undergo certification tests if levels recorded during a test exceed published injury reference values or the values achieved in dummy certification tests, or if postcrash inspection reveals damage. All visible damage is repaired before the dummy is used again.

The dummies and vehicle are kept in a temperature-controlled area where the temperature is maintained at 20.0–22.2 degrees Celsius and the relative humidity at 10%–70% for at least 16 hours prior to the test. The driver dummy's head, knees, and shins and the left rear dummy's head and knees are colored with grease paint to facilitate postcrash identification of impacts with the vehicle interior. Photographic targets are placed on both sides of the head to mark the location of its center of gravity.

Seat belt placement

If adjustable, the driver shoulder belt upper anchorage point should be positioned according to the manufacturer's recommendation or set in the topmost position. Details on the placement procedure for the driver lap and shoulder seat belt can be found in the *Guidelines for Using the UMTRI ATD Positioning procedure for ATD and Seat Positioning (Version VI)* (IIHS, 2022b).

The left rear-occupant shoulder belt upper anchorage point, if adjustable, should be positioned according to the manufacturer's recommendation or set in the lowest position. Details on the placement procedure for the left rear-occupant lap and shoulder seat belt can be found in the *Dummy Seating Procedure for Rear Outboard Positions (Version II)* (IIHS, 2022a).

Photography

Still photography

The precrash and postcrash conditions of each test vehicle are photographed. Two precrash views and two postcrash views show the side and left front quarter of the test vehicle.

Additional photographs document the precrash position of the driver and left rear dummy, including close-up views of the driver dummy's legs and the left rear dummy's lap and shoulder belt positioning.

Three standard views of the vehicle in its postcrash position in front of the barrier are recorded. Additional photographs document the postcrash position of the driver dummy.

High-speed video

Ten high-speed digital imagers along with real-time cameras record video of the test. The coordinates and lens focal length of each offboard high-speed camera are listed in Table 1. The camera position and lens focal length of each onboard high-speed camera are listed in Table 2. All high-speed imagers record at 500 frames per second. The positions of the offboard and onboard cameras are shown in Figure 6A and 6B, respectively.

Table 1
Offboard high-speed cameras — Coordinates, focal points, and settings

	A	B	C	D	E	F	G
Camera position	Overhead	Driver perp- endicular	Driver rear oblique	Barrier/ block	Passenger perpen- dicular	Passenger oblique	Driver front oblique
Coordinate X (cm)	0	-100	-750	300	-100	885	200
Coordinate Y (cm)	0	1440	1075	-150	1660	-915	500
Coordinate Z (cm)	900	150	125	235	Variable	160	220
Focal length (mm)	35	50	75	25	85	75	35

Table 2
Onboard high-speed cameras — Focal points and settings

	H	I	J	K
Camera position	Passenger door (front)	Inside roof, oblique	Inside roof, straight	Passenger door (rear)
Focal point	Side view of driver	Angled view of rear occupant from right front passenger, knees to roof	Front view of rear occupant from vehicle center, knees to above head restraint	Side view of rear occupant and excursion lines on left rear-passenger door; aligned 50 ± 5 mm behind front seatback line
Focal length (mm)	12.0	8.5	8.5	8.5

Figure 6A
Offboard high-speed camera positions

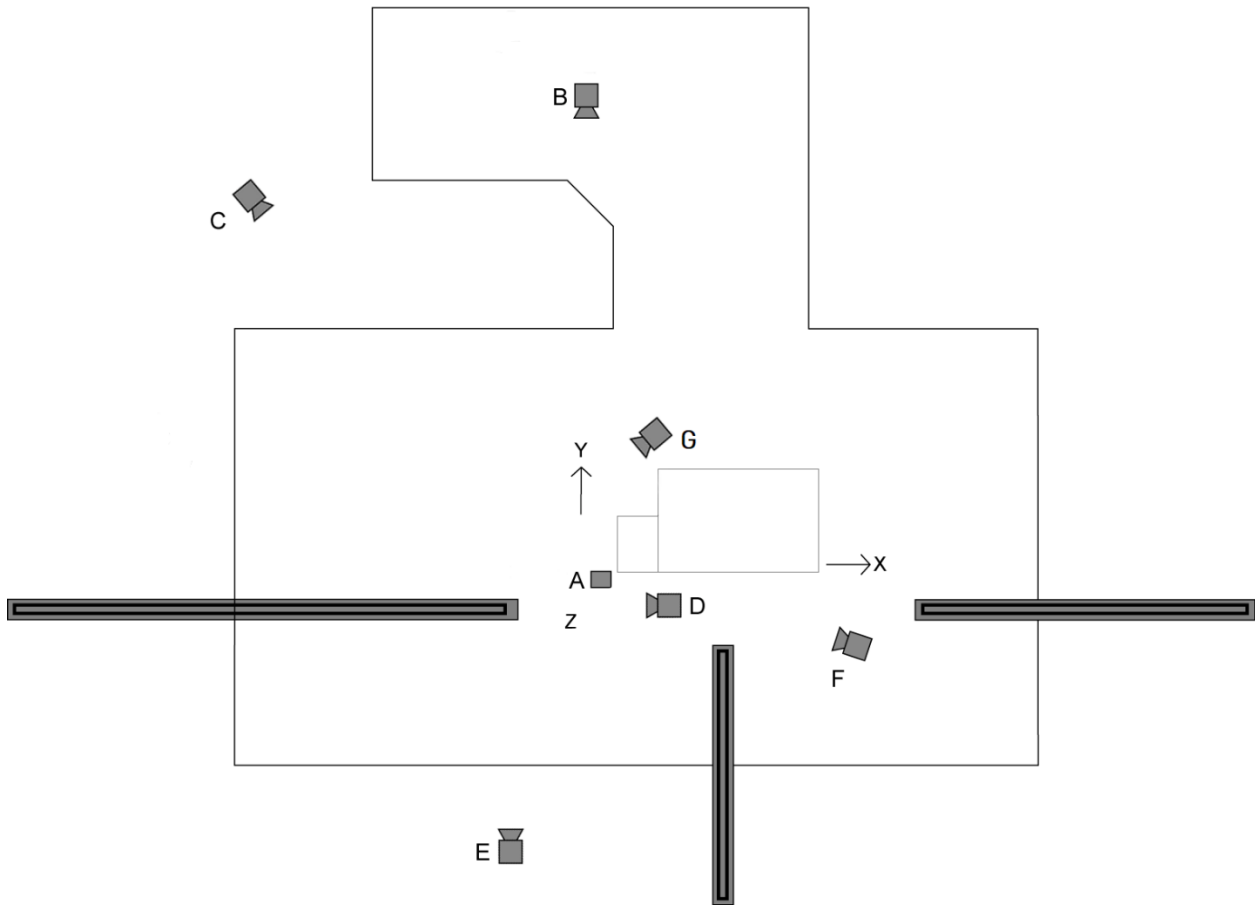
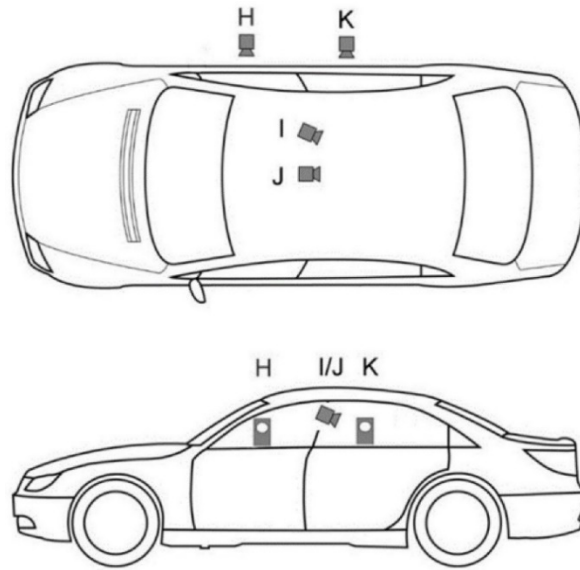

Figure 6B
Onboard high-speed camera positions



MEASUREMENTS AND OBSERVATIONS

Test weight

The test weight of the vehicle is measured at each of the four wheels. The vehicle is weighed with all test equipment installed including both dummies. The front and rear axle weights are used to determine the longitudinal position of the center of gravity for the test vehicle.

Impact speed

The impact speed of the vehicle is determined by sensors in the crash propulsion system. Alternately, video analysis or external speed measurement devices can be used to determine the vehicle's impact speed.

Overlap

The test overlap is verified from the video taken by the high-speed digital-imager overhead view (position A in Figure 6A). At the time of impact, the outboard edge of the deformable barrier (Figure 7) should fall within the 39% and 41% vehicle-width tape on the front of the vehicle. If the target falls outside of this area, additional analysis is conducted to determine the actual offset.

Figure 7
Determining vehicle overlap — Video screen shot



Fuel system integrity

Observations about fuel system integrity are recorded for each test. Any Stoddard solvent leaked from the fuel system within 1 minute after the impact is collected as the first sample. This typically is done by soaking up the fluid with an absorbent pad of known mass. The second sample of leaked Stoddard fluid is collected during the 5 minutes immediately following the collection of the first sample. This sample typically is collected in pans placed under the sources of identified leaks. The third sample is collected during the 25 minutes immediately following the collection of the second. The pans used to collect the second sample are replaced with clean empty pans. The volume of each sample is determined by dividing the weight of the sample by the density of Stoddard solvent (790 g/l). The elapsed time is determined

using a stopwatch. The entire process is recorded with a video camera equipped with an internal timer, which displays the time in each frame.

High-voltage system integrity

Vehicles with a hybrid or full-electric drivetrain are monitored to ensure the high-voltage electrical system has not been compromised. Postcrash observations include a measure of electrolyte spillage (if any), battery retention, and electrical isolation of the high-voltage system as per FMVSS 305. Additionally, the battery temperature is monitored to detect any rapid increase in temperature that may indicate a thermal-runaway condition.

Intrusion measurements

A total of 14 locations are marked on the driver side interior and exterior of the vehicle, and their longitudinal, lateral, and vertical coordinates are recorded using a coordinate measurement machine (CMM). These same marks are measured after the crash using the same reference coordinate system. Intrusion of the steering wheel, instrument panel, and footwell relative to the driver is calculated by subtracting the average component displacements (difference between precrash and postcrash coordinates) of the four seat-attachment bolts, which are measured relative to the primary coordinate system, from the respective components of displacement for each of the target locations.

Coordinate system definition

A right-handed, three-axis orthogonal coordinate system is used for these measures: longitudinal (front to rear is positive), lateral (left to right is positive), and vertical (bottom to top is positive). The precrash coordinate system is defined with the vehicle unloaded (no occupants) on a level floor. The plane of the ground is used to define the X-Y plane, and the two end points on the centerline of the roof are used to define the X-axis.

Coordinates of three marked reference points inside the vehicle compartment are recorded precrash to establish the postcrash coordinate system. For most vehicles, the reference points are taken on the right rear-passenger-side door, or the vehicle structure below the rear-passenger-seatpan cushion.

Measurement point locations

The following are the locations for measuring vehicle intrusion:

Steering column (one point): The marked reference is the geometric center of the steering wheel, typically on the airbag door. After the crash, this point is measured by folding the airbag doors back into their undeployed position. In most cases, this measurement is probably less than the maximum intrusion into the compartment. However, if the steering column has loosened (from release of the adjustment lever), or completely separates from the instrument panel (due to shear module separation, for example) during the crash, the steering column postcrash measurement is taken by placing and holding the wheel and column in its approximate maximum dynamic position, upward and forward. High-speed video may be used to determine the approximate steering column position; however, the video footage may not always show clearly where the column was during the crash, and in such cases, other clues would be needed to reposition the column for measurement. In rare instances, it may not be possible to obtain any meaningful postcrash measurement.

Lower instrument panel (two points): The left and right lower instrument panel (knee bolster) lateral coordinates are defined by adding 15 cm to and subtracting 15 cm from the steering column reference lateral coordinate, respectively. The vertical coordinate is the same for both left and right references and is defined as 45 cm above the height of the floor (without floormats). If the panel or knee bolster loosens

or breaks away in the crash, the postcrash measurements are taken by pressing and holding the panel against the underlying structure.

Brake pedal (one point): The geometric center of the brake pedal pad (top surface) is measured. If the brake pedal is constructed so that it dangles loosely after the crash, the brake pedal is pushed straight forward against the toepan/floorpan and held there to take the postcrash measurement. If the pedal drops away entirely, no postcrash measurement is taken.

For vehicles with a manual transmission, the clutch pedal is also measured, and the pedal with the most resultant intrusion postcrash is used for the final rating.

Toepan (three points): The vertical coordinate for all toepan measurement locations is the vertical coordinate of the brake pedal reference. The lateral coordinates of the left, center, and right toepan locations are obtained by adding 15 cm to, adding 0 cm to, and subtracting 15 cm from the brake pedal reference lateral coordinate, respectively. The longitudinal coordinate is measured, and a mark is temporarily placed at the locations on the toepan. A utility knife is used to cut a small “v” in the carpet and underlying padding at each point on the toepan. The point of the “v” is peeled back, and the exposed floor is marked and measured. The carpet and padding are then refitted prior to the crash.

Left footrest (one point): The vertical coordinate for the footrest measurement location is the vertical coordinate of the brake pedal reference. The lateral coordinate of the footrest is obtained by adding 25 cm to the brake pedal reference lateral coordinate. The same procedure described for cutting the carpet under *Toepan (three points)* is used to mark and measure the underlying structure. In cases where there is a specific footrest construct at the footrest measurement location, the construct is removed and the underlying structure is marked and measured. The construct is reinstalled prior to the crash.

Seat bolts (typically, four points): Each of the four (or fewer) bolts that anchor the driver seat to the floor of the vehicle are measured.

A-pillar (one point): The A-pillar is marked on the inside of the door opening of the vehicle, at the vertical coordinate as the base of the left front window.

B-pillar (one point): The B-pillar is marked on the inside of the door opening of the vehicle, at the longitudinal center of the pillar at the same vertical coordinate as the A-pillar mark.

Dummy kinematics, contact locations, and kinematic assessments

Each dummy is inspected in its undisturbed postcrash position. Any damage to the dummy or unusual dummy resting-position information is noted. Dummy grease paint deposits on the vehicle interior are used to confirm contact locations between the dummy’s head, knees, and lower legs and the vehicle interior. The high-speed video is used to analyze dummy kinematics and to estimate the timing of notable events. For each event, the camera that provides the clearest view of the event is used. The start of the crash is the first video frame from each camera in which the vehicle-mounted time-zero LEDs are illuminated. The time recorded for each event is based on the number of frames elapsed from the start of the crash and the nominal operating speed of the camera. For the cameras operating at 500 frames/second, the estimate of the crash start time can be up to 2 ms late, and the event timing, as determined from the video, can be early or late by 2 ms.

Driver

The time of frontal airbag deployment, full inflation, and first dummy contact are recorded as well as any other notable events (e.g., thorax and knee airbag deployment, rebound contacts, etc.).

Left rear occupant

The deployment time for the side curtain airbag is recorded as well as any other notable events. Submarining of the occupant's pelvis under the lap belt is assessed using onboard camera views and ASIS and lap belt load cell data. Occupant head excursion is assessed using vertical tapeline boundaries on the interior of the left rear-occupant door in combination with an orthogonally positioned high-speed digital camera (K in Figure 6B) aligned longitudinally 50 ± 5 mm behind the front seatback line. Details on the assessment of submarining and occupant head excursion can be found in the *Moderate Overlap Crashworthiness Evaluation 2.0 Rating Guidelines, Version I* (IIHS, 2023).

SENSOR DATA COLLECTION

Vehicle accelerations

The linear accelerations in three orthogonal directions (longitudinal, lateral, and vertical) of the vehicle occupant compartment are measured by triaxial piezoresistive accelerometer arrays (Endevco 7264A-2000 or 7264B-2000 or an alternative that meets performance specifications). Positive vehicle accelerations are forward along the longitudinal axis, to the right along the lateral axis, and downward along the vertical axis. The data are presented filtered according to the channel frequency class (CFC) 60 as defined in SAE (2014) Surface Vehicle Recommended Practice J211/1.

Seat belt load cells

Shoulder belt and lap belt tension are measured for the driver and left rear occupant using seat belt load cells (Messring 5BC-D16-21A, Humanetics 3255LN2, or equivalent). The shoulder belt sensor should be positioned on the outboard side above the shoulder with enough clearance to prevent interaction with the shoulder, belt D-ring, or vehicle trim during belt tensioning (if applicable) and loading. The lap belt sensor should be positioned on the outboard side in the position least likely to interfere with the dummy's pelvis, the seat, or the vehicle trim during belt tensioning (if applicable) and loading. The data are presented filtered according to the channel frequency class (CFC) 60 as defined in SAE (2014) Surface Vehicle Recommended Practice J211/1.

Pressure mat sensor

Belt position and pressure on the rear-occupant chest is measured using a high-frequency pressure mat (XSensor HX210:36.48.05M-HSS incorporated into a vest fitted for the H35F or equivalent). The pressure mat on the H35F is adhered to the chest jacket on the shoulders and sides so that the pressure-sensing region does not move relative to the chest jacket. The pressure mat is oriented and landmarked prior to testing according to the procedure in the Appendix, so that the belt position can be measured relative to dummy landmarks.

Dummy responses

H350M dummy measurements

Each H350M dummy is equipped with instrumentation for measuring the following:

Head

Triaxial accelerations (three Endevco 7264A-2000 [or 7264B-2000] accelerometers or an alternative that meets performance specifications)

Triaxial angular rate sensors (three DTS ARS Pro – 18k or an alternative that meets performance specifications)

Neck

A-P and L-M shear force and axial force (Humanetics Innovative Solutions, Inc. Model 2564 or 1716A upper neck load cell)

A-P moments (Humanetics Innovative Solutions, Inc. Model 2564 or 1716A upper neck load cell)

Chest

Triaxial accelerations (three Endevco 7264A-2000 [or 7264B-2000] accelerometers or an alternative that meets performance specifications)

Rib compression

Lower extremities

Femur axial forces (Humanetics Innovative Solutions, Inc. Model 2121A load cell)

Tibia-femur displacements

Upper tibia A-P and L-M moments (Humanetics Innovative Solutions, Inc. Model 1583 load cell)

Lower tibia axial force, A-P and L-M moments (custom Humanetics Innovative Solutions, Inc. Model 3093 load cell)

Biaxial foot accelerations (A-P and I-S) (two Endevco 7264A-2000 [or 7264B-2000] accelerometers or an alternative that meets performance specifications)

H35F dummy measurements

Each H35F dummy is equipped with instrumentation for measuring the following:

Head

Triaxial accelerations (three Endevco 7264A-2000 [or 7264B-2000] accelerometers or an alternative that meets performance specifications)

Triaxial angular rate (three DTS ARS Pro – 18k or an alternative that meets performance specifications)

Upper neck

A-P shear force and axial force

A-P moment

Lower neck

A-P shear force and axial force (Humanetics Innovative Solutions, Inc. Model 5045J lower neck adjustable load cell)

A-P moment (Humanetics Innovative Solutions, Inc. Model 5045J lower neck adjustable load cell)

Chest

Triaxial accelerations (three Endevco 7264A-2000 [or 7264B-2000] accelerometers or an alternative that meets performance specifications)

Rib compression

Y-axis angular rate (DTS ARS Pro – 18k or an alternative that meets performance specifications)

Thoracic spine

A-P shear force and axial force

A-P moment

Lumbar spine

A-P shear forces and axial force

A-P moment

Pelvis

Triaxial accelerations (three Endevco 7264A-2000 (or 7264B-2000) accelerometers or an alternative that meets performance specifications)

Left and right ASIS A-P shear forces and ASIS A-P moments

Y-axis angular rate (DTS ARS Pro – 18k or an alternative that meets performance specifications)

Lower extremities

Femur axial forces

Instrument calibration

All instruments are regularly calibrated to a known standard.

Accelerometers, load cells, and angular rate sensors are calibrated every 12 months. All measurements recorded from these instruments comply with the recommendations of SAE (2018) Surface Vehicle Information Report J1733.

Pressure sensors are calibrated every 12 months.

Data acquisition

The H350M and H35F dummies use an internal data acquisition system for dummy-sensor data acquisition. A separate data acquisition system, mounted inside the vehicle, is used for data acquisition of all vehicle and belt sensors.

During the crash, all dummy and vehicle measurements are recorded at a sample rate of 10 kHz per channel. Pressure mat target frequency is 3.3 kHz. Signals in all channels convert simultaneously, so the time reference for different channels is not skewed.

After the data have been downloaded, any dummy or vehicle initial sensor offset from zero is removed from each channel by computing the mean value for 100 data points preceding the crash event (from 100 to 90 ms before impact) for each channel and subtracting each mean from the respective data channel. The data are digitally filtered using the frequency response classes recommended in SAE (2014) Surface Vehicle Recommended Practice J211/1; foot accelerations are filtered to CFC 180. All filtering and subsequent calculations are executed using DIAdem (National Instruments Corporation).

Additional calculations

In addition to summary metrics for each of the recorded data channels, the following calculations are made:

- Vector resultant of the head acceleration
- 3-ms clip of the vector resultant head acceleration
- Head injury criterion (HIC-15)
- Neck Nij (calculated using formulas presented in 65 Fed. Reg. 30680 [2000])
- Vector resultant of the spine accelerations
- 3-ms clip of the vector resultant thoracic spine acceleration
- Viscous criterion
- Sternum deflection rate
- Vector resultant of the tibia-bending moments (using the adjusted tibia A-P moments [Zuby et al., 2001]) (driver only)
- Tibia index (using the adjusted tibia A-P moments (Zuby et al., 2001) (driver only)
- Vector resultant of the foot accelerations (driver only)

All calculations comply with the recommendations of SAE (2015) Surface Vehicle Recommended Practice J1727. The sternum deflection rate is calculated from the sternum deflection filtered to CFC 60.

For the rear dummy only, shoulder belt position at maximum chest deflection and maximum dynamic belt movement are calculated using data from the pressure sensor. This procedure is outlined in the Appendix of the *Moderate Overlap Crashworthiness Evaluation 2.0 Rating Guidelines, Version I* (IIHS, 2023).

REFERENCES

- Insurance Institute for Highway Safety. (2021). *Test vehicle selection (Version I)*.
- Insurance Institute for Highway Safety. (2022a). *Dummy seating procedure for rear outboard positions (Version II)*.
- Insurance Institute for Highway Safety. (2022b). *Guidelines for using the UMTRI ATD positioning procedure for ATD and seat positioning (Version VI)*.
- Insurance Institute for Highway Safety. (2023). *Moderate overlap crashworthiness evaluation 2.0 rating guidelines (Version I)*.
- Society of Automotive Engineers. (2009). *Surface vehicle recommended practice J1100; Motor vehicle dimensions*.
- Society of Automotive Engineers. (2013). *Surface vehicle information report J2921; H-III5F chest jacket harmonization*.
- Society of Automotive Engineers. (2014). *Surface vehicle recommended practice J211/1; Instrumentation for impact test, Part 1: Electronic instrumentation*.
- Society of Automotive Engineers. (2015). *Surface vehicle recommended practice J1727; Calculation guidelines for impact testing*.
- Society of Automotive Engineers. (2018). *Surface vehicle information report J1733; Sign convention for vehicle crash testing*.
- Zuby, D. S., Nolan, J. M., & Sherwood, C. P. (2001). *Effect of Hybrid III leg geometry on upper tibia bending moments* (SAE Technical Paper Series 2001-01-0169). Biomechanics Research and Development (SP-1577) Society of Automotive Engineers.

APPENDIX: INSTALLING THE PRESSURE SENSOR

Step 1: Establishing the dummy thorax coordinate system

A right-handed, three-axis orthogonal coordinate system fixed to the H35F dummy's uncompressed thorax is used to calculate shoulder belt position measures. The positive X-axis is directed from posterior to anterior (P-A), the positive Y-axis is directed from left to right (L-R), and the positive Z-axis is directed from superior to inferior (S-I). The accuracy and repeatability of the coordinate system is checked periodically when a thorax calibration is performed and/or a part is replaced in the thorax assembly.

The following procedure is used to set up the coordinate system:

- a) Remove the chest jacket from the H35F dummy.
- b) The top plane of the second rib is used to define the X-Y plane (Figure A1), the two bolt points on the back of the dummy are used to define the Y axis (Figure A2), and the origin is defined as the center of the right anterior-circular indent on the neck bracket (Figure A3).
- c) Coordinates of three marked reference points on the neck bracket (the center of the circular indents shown in Figure A4 [Points 1, 2, and 3], not including the origin shown in Figure A3) are recorded. Later on, these are used as recovery points to establish the thorax coordinate system once the chest jacket is installed on the dummy. Any similar points that do not move with respect to the dummy's thorax and can be accessed with the chest jacket and pressure sensor installed can be used as recovery points. Before installing the chest jacket, care should be taken to ensure that the recovery points repeatably reproduce the measurements taken in the initial set-up of the coordinate system.

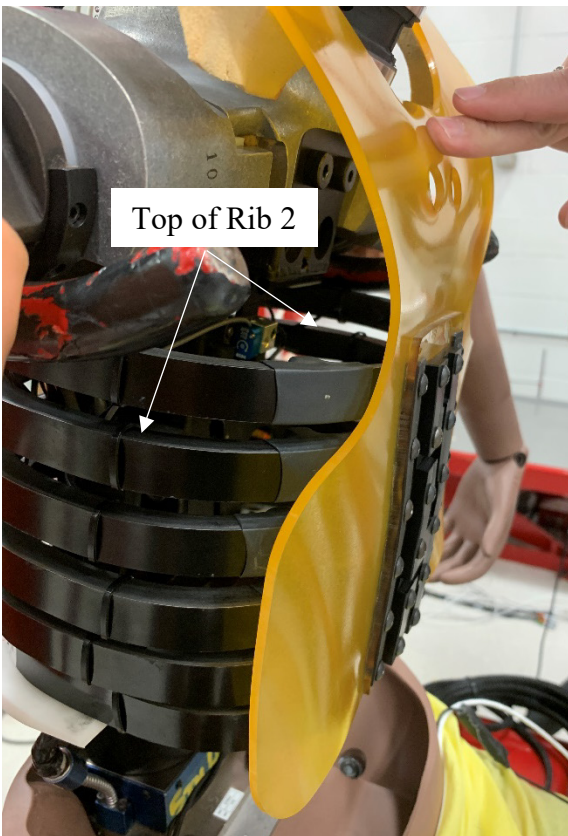

Figure A1. X-Y plane for dummy thorax coordinate system

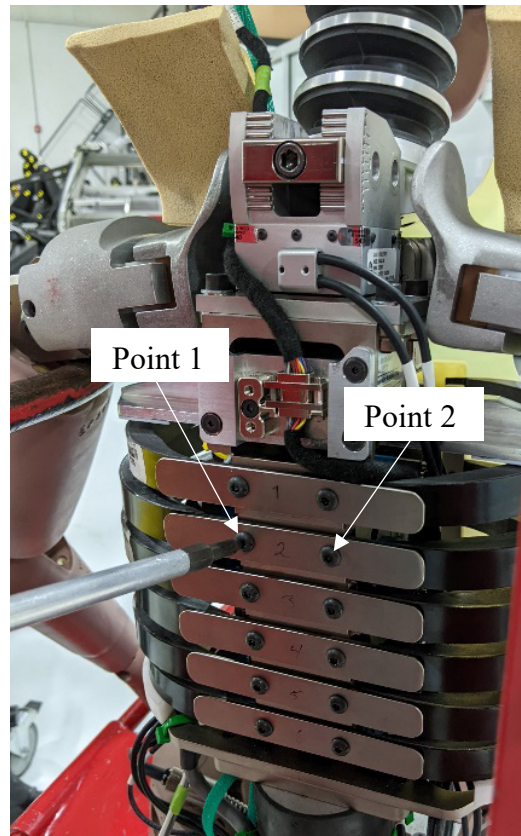

Figure A2. Y-axis for dummy thorax coordinate system

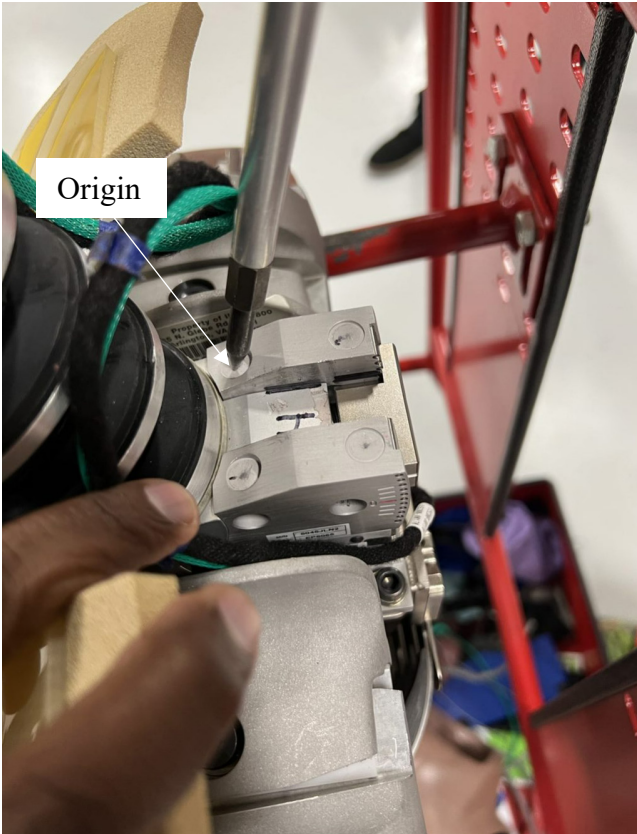

Figure A3. Origin for dummy thorax coordinate system

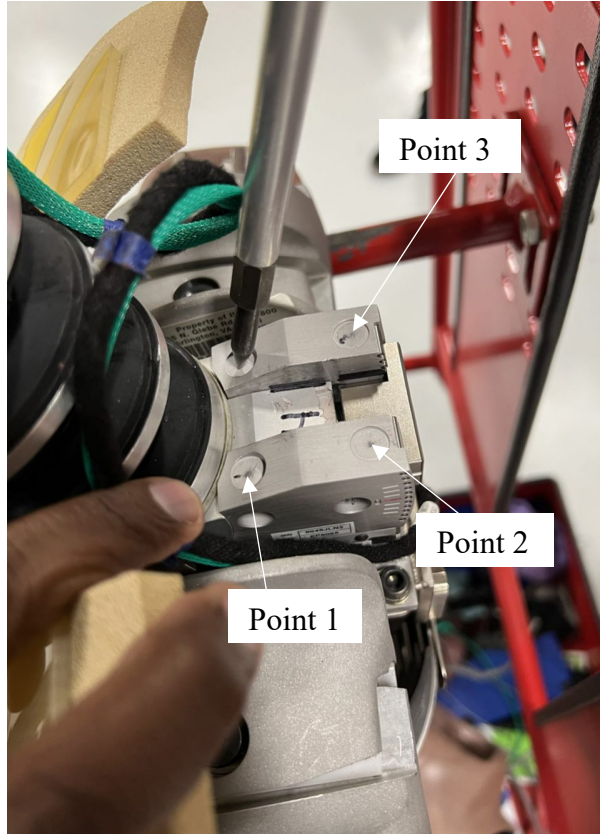

Figure A4. Reference points to establish dummy thorax coordinate system after the chest jacket is installed

**Figures A1 to A4
Establishing the dummy thorax coordinate system**

- d) The chest potentiometer location is defined as the approximate location of the hole on the transducer arm assembly (ball end) at rest (Figure A5). The chest potentiometer location is recorded and will be translated on the pressure sensor once the chest jacket and pressure-sensing mat is installed on the dummy's thorax.

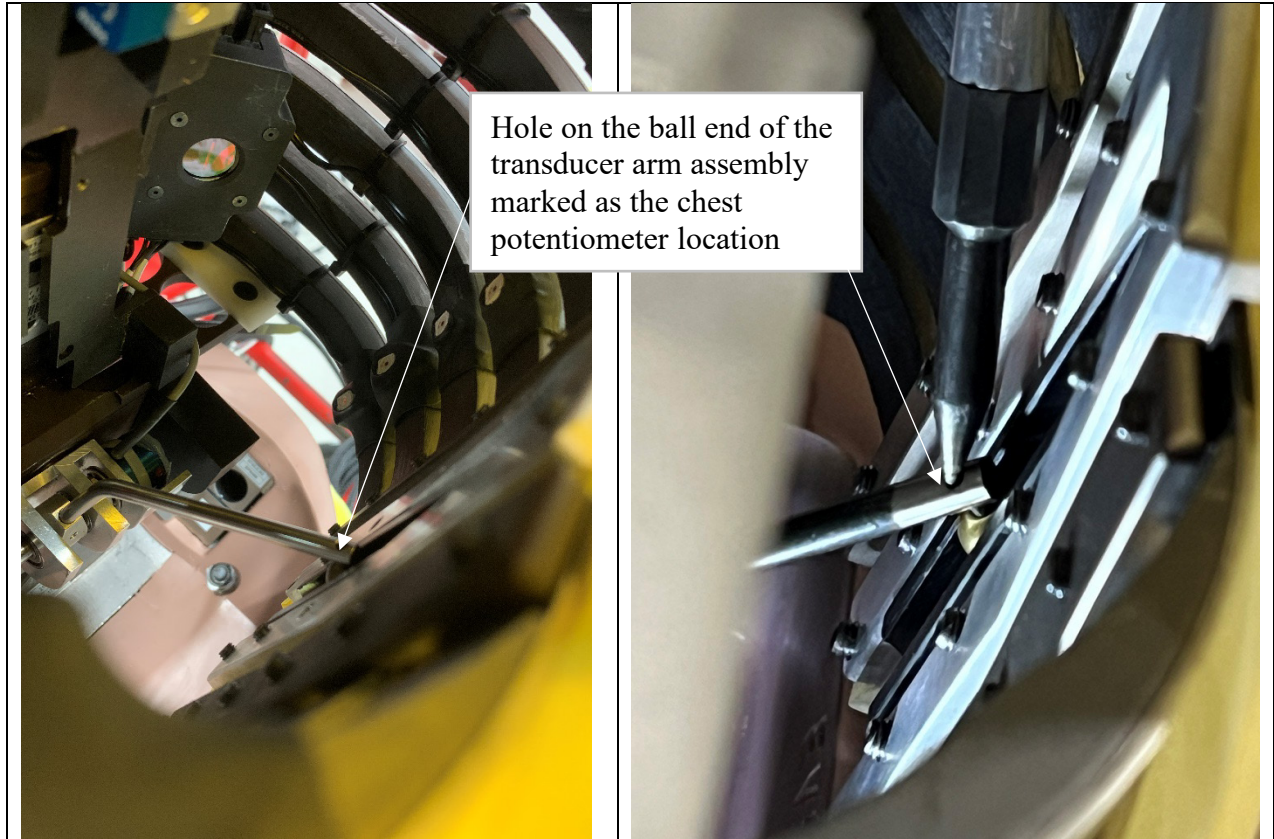

Figure A5
Chest potentiometer location

Step 2: Installing the chest jacket and pressure sensor on the dummy

- a) After setting up the coordinate system (Step 1), the chest jacket is installed on the H35F dummy.
- b) The centerline of the pressure sensor is aligned horizontally with the dummy centerline, and the top edge of the pressure sensor is approximately aligned with the top edge of the chest jacket (Figure A6).
- c) The pressure sensor is secured to the chest jacket by taping (with high-adhesion tape) the adhesion flaps on the underside of the sensor to the shoulders (Figure A7) and sides (Figure A8) and zippering the back (Figure A9).
- d) Using the three reference points recorded earlier (Step 1c, Figure A4), the chest potentiometer point is located and landmarked on the pressure mat. (Figure A10).

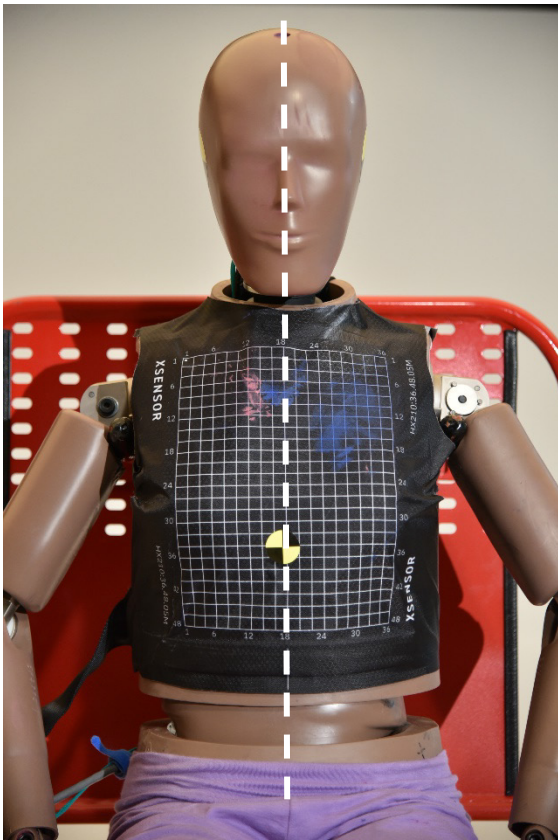

Figure A6. Center of the pressure sensor aligned with the dummy centerline and top edge of the sensor aligned with the top edge of dummy chest jacket

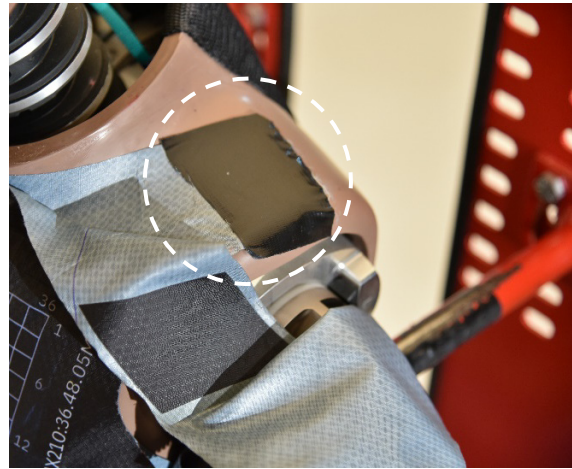

Figure A7. Securing the pressure sensor shoulder flaps (gray portion is underside of sensor.)

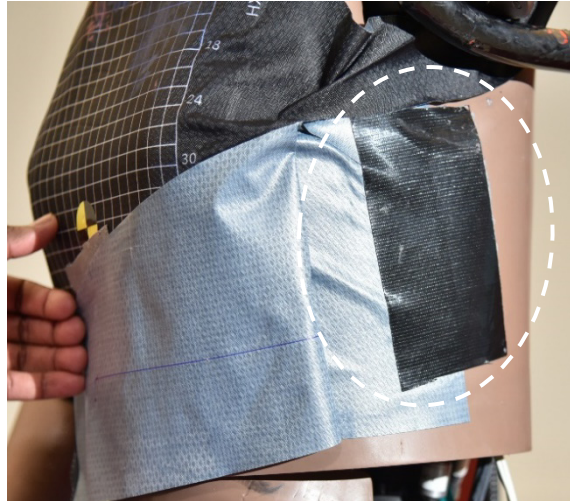

Figure A8. Securing the pressure sensor side flaps (gray portion is underside of sensor)



Figure A9. Securing the pressure sensor from the back

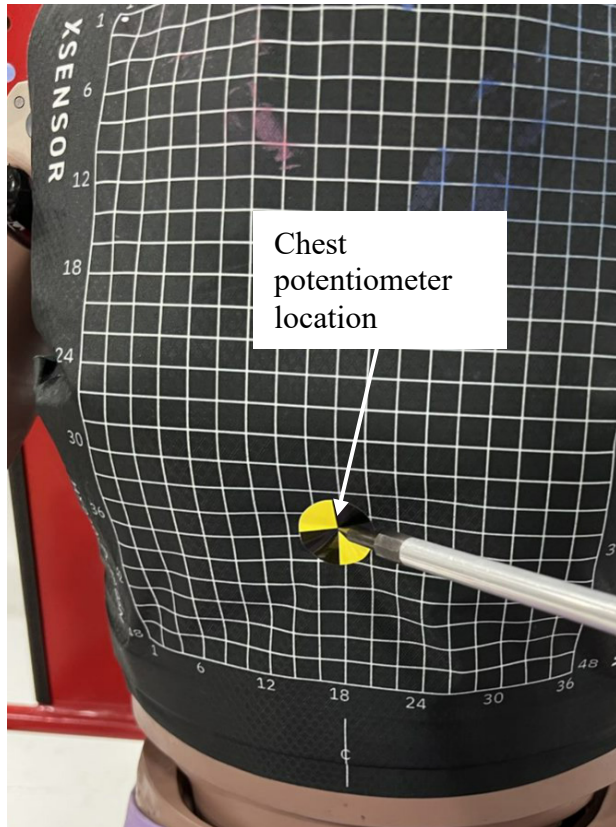

Figure A10. Recording the chest potentiometer and pressure sensor grid locations

**Figures A6 to A10
Installing the pressure sensor on the dummy**

- e) Using a CMM, the location of each row (each corner of the marked square gridlines) is recorded in the dummy thorax coordinate system (Figure A10). The marked gridlines have a resolution of 10 mm × 10 mm, while the pressure sensing elements have a resolution of 5 mm × 5 mm. The data from two consecutive gridlines is interpolated to obtain the location of the sensor element in between the gridlines. Figure A11 shows this interpolation for one square grid marked on the pressure sensor (2 × 2 sensors). The lower right corner is used as the reference location for each individual sensel.

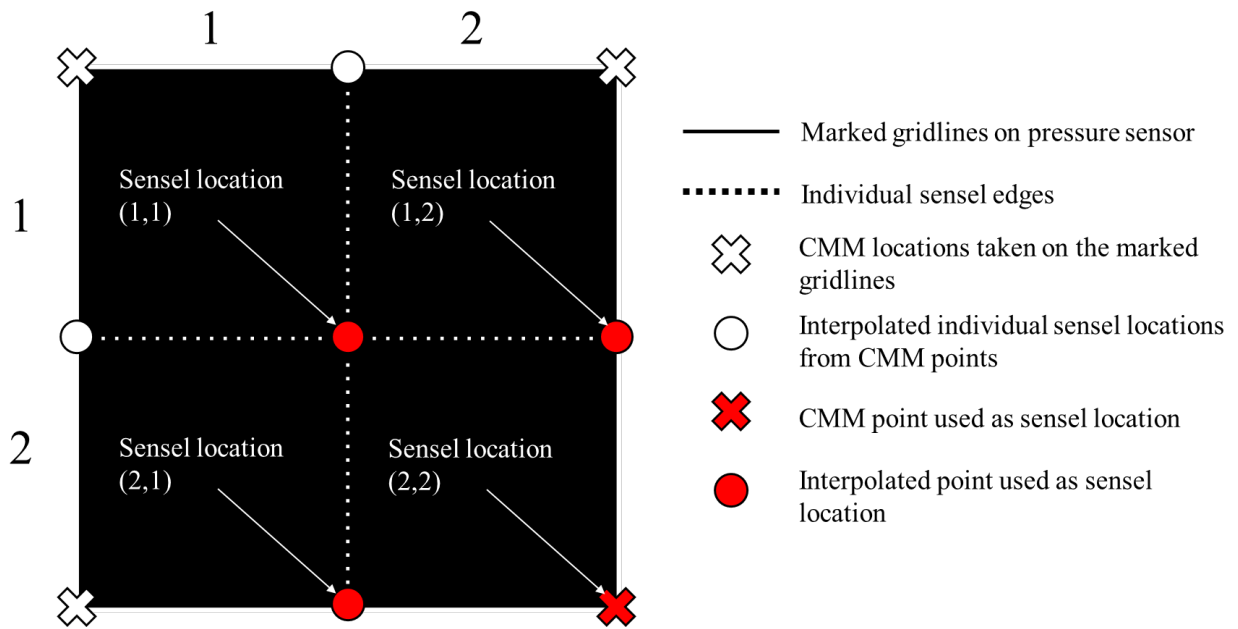

Figure A11. Individual sensel location

- f) Before each test, it is confirmed that the pressure-sensing mat has not significantly deviated from the position recorded earlier. The chest potentiometer location and the locations on the pressure sensor grid are recorded each time the pressure-sensing mat is installed on the dummy or in case the pressure-sensing mat has significantly deviated from the position recorded earlier.