

Side Impact Crashworthiness Evaluation 2.0

Moving Deformable Barrier Specification, Version 2.0

DRAFT

May 2020



Insurance Institute for Highway Safety

988 Dairy Road

Ruckersville, VA 22968

researchpapers@iihs.org

+1 434 985 4600

iihs.org



Contents

DOCUMENT REVISION HISTORY	2
SCOPE.....	3
PURPOSE.....	3
GENERAL DESCRIPTION	3
BARRIER COMPONENT DIMENSIONS AND SPECIFICATIONS.....	3
Main Honeycomb Block	4
Bumper Honeycomb Block.....	4
Sheet Metal.....	4
ADHESIVE BONDING PROCEDURE.....	5
Bonding Strength Tests	5
CONSTRUCTION.....	5
BARRIER IDENTIFICATION AND MARKING.....	5
Barrier Certification	5
REFERENCES	6
FIGURES	7

DOCUMENT REVISION HISTORY

Revisions to the April 2020 DRAFT

Due to manufacturing constraints, the following changes were made to the type and tolerances allowed for the movable deformable barrier materials:

- For the dimensions of the movable deformable barrier in Figure 2, the tolerance of ± 0.5 degrees was removed.
- The Main Honeycomb Block specification was changed as follows:
 - Upper Element, Rail Elements, and Middle Bottom Element: The tolerances allowed for the cell size ($\pm 10\%$) and density (± 4 kg/m³) were removed.
 - Rail Elements and Middle Bottom element: Aluminum 5052 was removed as an option for the material.
- For all elements of the Bumper Honeycomb Block (Bumper Middle Element and Bumper Side Elements):
 - The tolerances allowed for the cell size ($\pm 10\%$) and density (± 4 kg/m³) were removed.
 - Aluminum 5052 was removed as an option for the material.

SCOPE

This specification describes an updated version of the moving deformable barrier to be used in the Insurance Institute for Highway Safety (IIHS) side impact crashworthiness evaluations.

PURPOSE

The design and performance criteria described in this specification are intended to

- provide a measurement tool with sufficient precision to ensure repetitive and correlative results under similar test conditions and
- reflect adequately the protective performance of a motor vehicle or item of motor vehicle equipment with respect to human occupants.

GENERAL DESCRIPTION

The side impact moving deformable barrier consists of two parts: a *Main Honeycomb Block* and a *Bumper Honeycomb Block*.

The *Main Honeycomb Block* comprises four elements: one Upper, two Rails, and one Middle Bottom.

The *Bumper Honeycomb Block* comprises three elements: one Middle and two Sides.

An expanded view of the barrier components is shown in Figure 1. Barrier construction and assembly drawings (Figures 2 to 5) are included at the end of this specification.

BARRIER COMPONENT DIMENSIONS AND SPECIFICATIONS

The dimensions of the moving deformable barrier are illustrated in Figure 2. All dimensions in Figure 2 allow a tolerance of ± 5 mm (where applicable) unless otherwise specified.

Honeycomb crush strengths are measured in accordance with the certification procedure described in *U.S. Department of Transportation, NHTSA Lab Test Procedure for FMVSS No. 214, Dynamic Side Impact Protection: Moving Deformable Barrier Test Requirements, TP-214D, Appendix C**.

* For the *Upper Element* of the IIHS movable deformable barrier, sample sizes were increased to 250 x 250 mm due to cell size. All other dimensions and tolerances remain as stated in NHTSA *TP-214D, Appendix C*.

Main Honeycomb Block

The *Main Honeycomb Block* is manufactured from four elements to exhibit the length, width, and height dimensions shown in Figure 2 and consists of the following:

- ***Upper Element***

The *Upper Element* is manufactured out of aluminum 3003 with nominal specification as follows: cell size of 25.4 mm, density of 20.8 kg/m³, and crush strength of 140 ± 16 kPa.

- ***Rail Element***

The two *Rail Elements* are manufactured out of aluminum 3003 with nominal specification as follows: cell size of 9.5 mm, density of 64.1 kg/m³, and crush strength of 1100 ± 88 kPa.

- ***Middle Bottom Element***

The *Middle Bottom Element* is manufactured out of aluminum 3003 with nominal specification as follows: cell size of 19.1 mm, density of 28.9 kg/m³, and crush strength of 325 ± 26 kPa.

Bumper Honeycomb Block

The *Bumper Honeycomb Block* is manufactured from three elements to exhibit the length, width, and height dimensions shown in Figure 2 and consists of the following:

- ***Bumper Middle Element***

- ***Bumper Side Element***

The *Bumper Middle Element* and two *Bumper Side Elements* are manufactured out of aluminum 3003 with nominal specification as follows: cell size of 19.1 mm, density of 28.9 kg/m³, and crush strength of 325 ± 26 kPa.

Sheet Metal

All sheet metal dimensions have a ± 1 mm tolerance unless otherwise specified.

- ***Base Plate***

The *Base Plate* (Figure 3) is manufactured out of aluminum 5251 H22 or 5052 H32 (0.8 ± 0.05 mm). If an alternative alloy is used, proof of equivalency must be provided to IIHS.

- ***Top Cladding***

The *Top Cladding* (Figure 4) is manufactured out of aluminum 5251 H24 or 5052 H32 (0.7 ± 0.04 mm). If an alternative alloy is used, proof of equivalency must be provided to IIHS.

- ***Bumper Cladding***

The *Bumper Cladding* (Figure 5) is manufactured out of aluminum 5251 H22 or 5052 H32 (3.0 ± 0.07 mm). If an alternative alloy is used, proof of equivalency must be provided to IIHS.

ADHESIVE BONDING PROCEDURE

Prior to bonding, all aluminum sheets shall be degreased. The adhesive to be used throughout should be a two-part polyurethane. If an alternative bonding method is used, proof of equivalency must be provided to IIHS.

Bonding Strength Tests

- Flatwise tensile testing is used to measure the bond strength of the adhesive according to ASTM C297/C297M-16, Standard Test Method for Flatwise Tensile Strength of Sandwich Constructions.
- The test pieces should be 100 mm × 100 mm and 15 mm deep, bonded to a sample of the *Base Plate* material. The honeycomb used should be representative of the *Rail Element* within the impactor.
- The minimum bonding strength must be 0.6 MPa.

CONSTRUCTION

The *Main Honeycomb Block* is adhesively bonded to the *Base Plate*. The *Base Plate* extends beyond the height of the *Main Honeycomb Block* equally at the bottom and top, providing mounting flanges (Figure 3). The *Top Cladding* is adhesively bonded to the *Main Honeycomb Block*.

The three elements from the *Bumper Honeycomb Block* are adhesively bonded to the *Bumper Cladding* and the *Top Cladding* 50 mm from the bottom face.

The adhesive shall only be applied to the *Cladding* and *Base Plate* surfaces during bonding.

A maximum of 0.5 kg/m² of adhesive must be applied evenly over the surface, giving a maximum film thickness of 0.5 mm.

Care should be taken to ensure that adhesive does not run into the honeycomb cells, which causes an increase in the crush strength of the honeycomb.

BARRIER IDENTIFICATION AND MARKING

Each barrier shall carry a serial number that is stamped, etched, or otherwise permanently attached, from which the manufacturing details and version can be established.

Barrier Certification

Each barrier must have (included in its shipping container or in electronic format) a certification package available that provides information according to *U.S. Department of Transportation, NHTSA Lab Test Procedure for FMVSS No. 214, Dynamic Side Impact Protection: Moving Deformable Barrier Test Requirements, TP-214D, Appendix C*.

REFERENCES

ASTM International. (2016). *C297/C297M-16, Standard test method for flatwise tensile strength of sandwich constructions*. West Conshohocken, PA. Retrieved from <https://www.astm.org/CONTACT/index.html>

U.S. Department of Transportation. (2012). *NHTSA lab test procedure for FMVSS No. 214: Dynamic side impact protection: Moving deformable barrier test requirements, Appendix C (TP-214D)*.

DRAFT

FIGURES

Figure 1. Exploded view of the movable deformable barrier

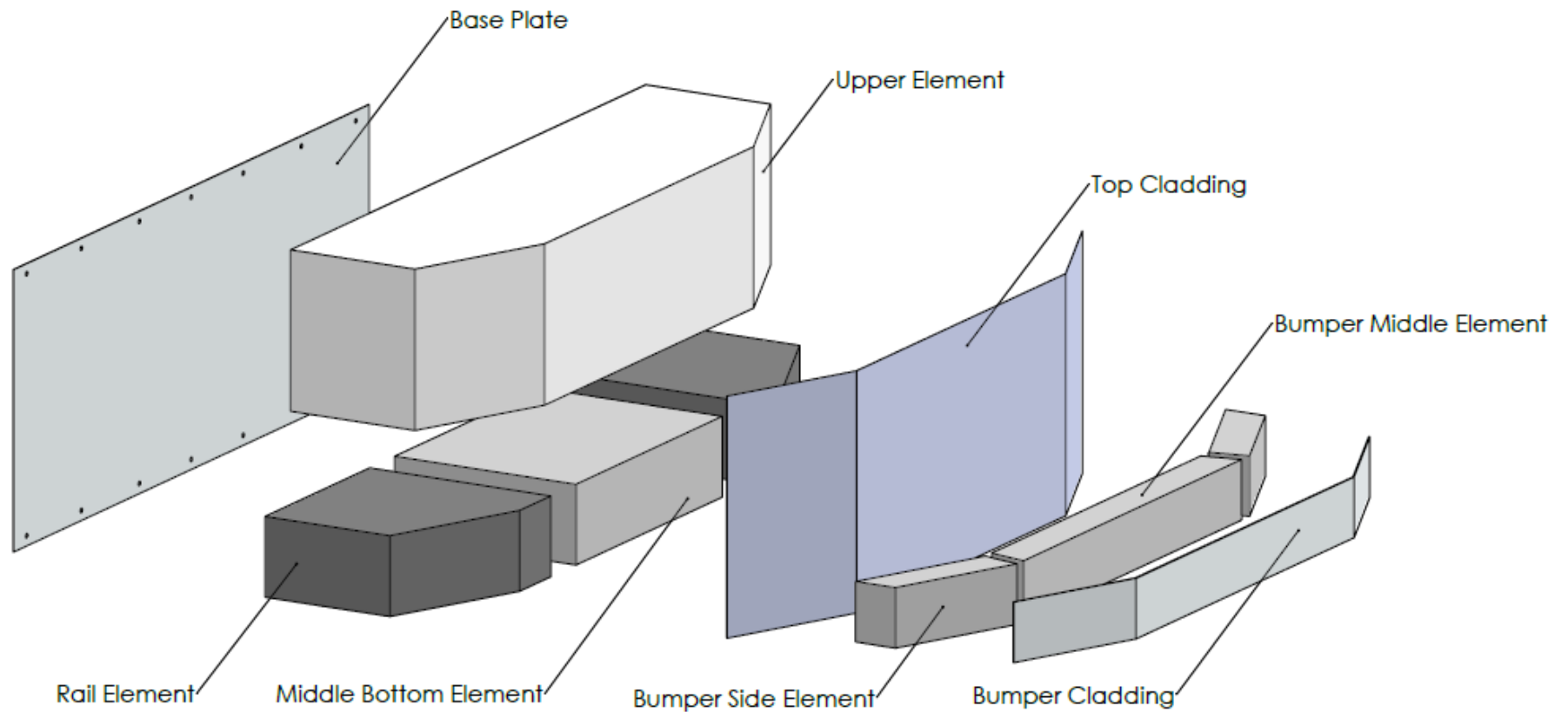

Figure 2. General assembly

Note 1: All dimensions and tolerances are for honeycomb only.

Note 2: All honeycomb elements have the same ribbon orientation.

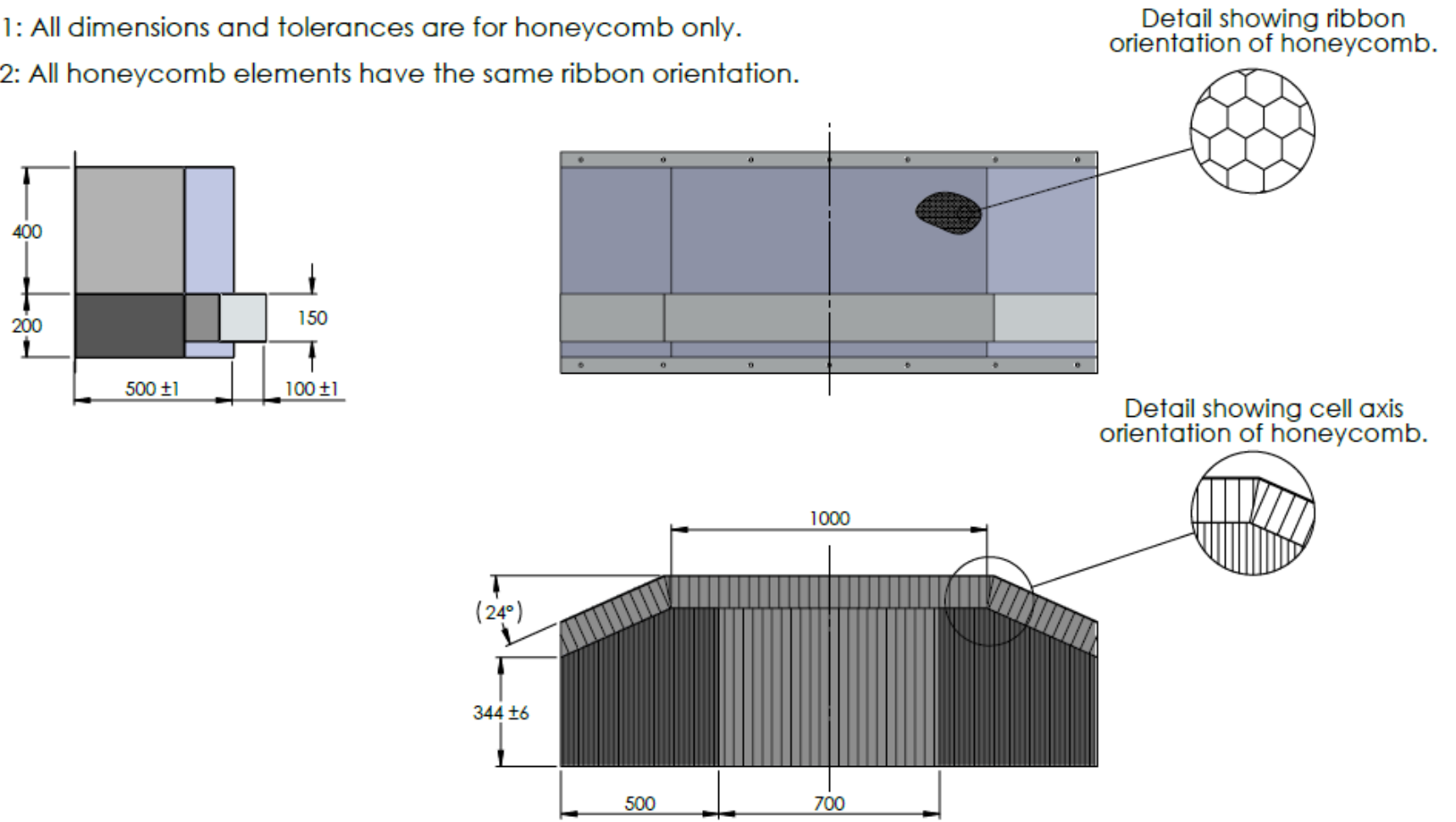

Figure 3. Base Plate and Mounting Flanges

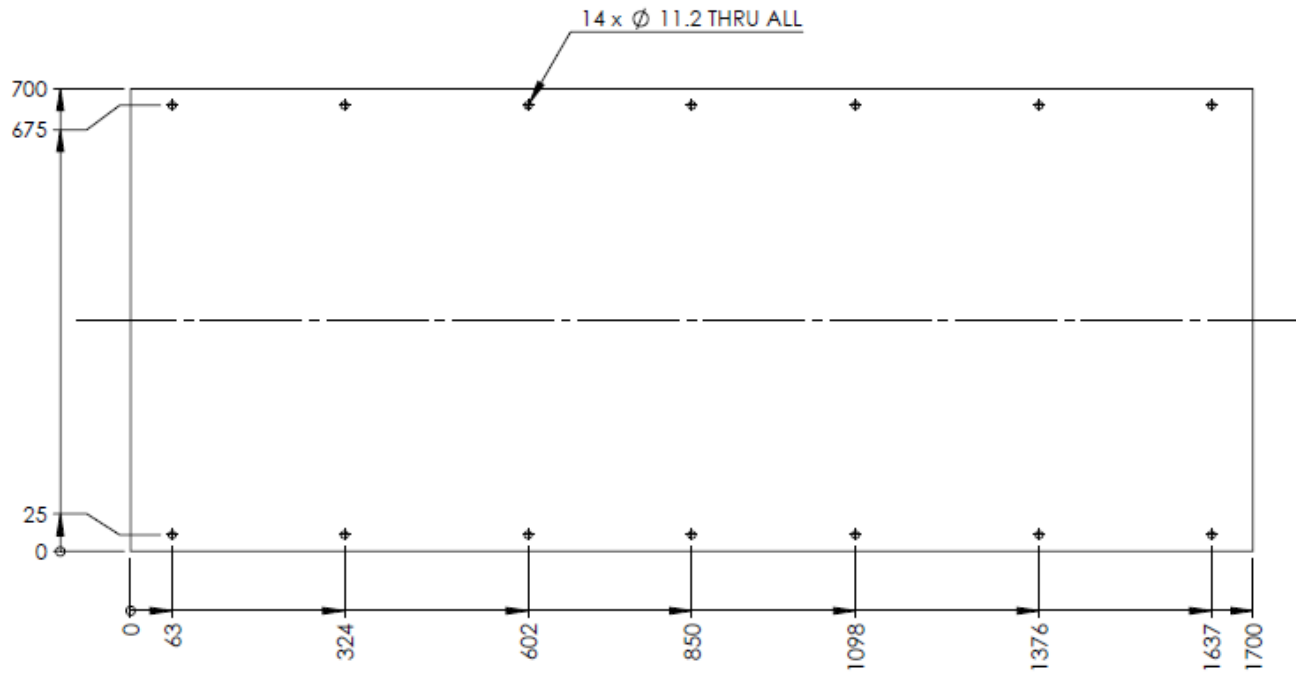

Figure 4. Top Cladding

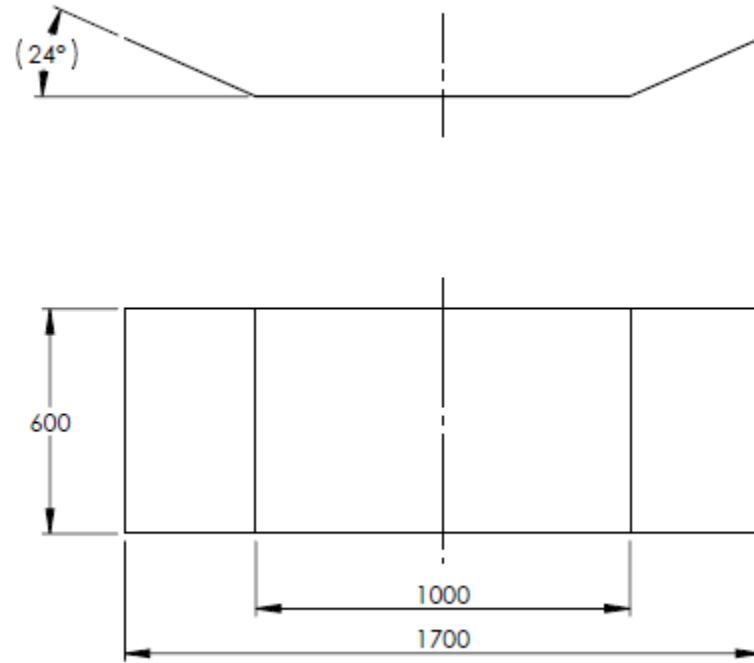

Figure 5. Bumper Cladding

