

IIHS LATCH Measurement Tool Set Drawings – REV1

REVISIONS			
REV.	DESCRIPTION	DATE	BY
A	ADD STORAGE CASE. CHANGE IIHS LOGO.	2/1/2017	RGJ

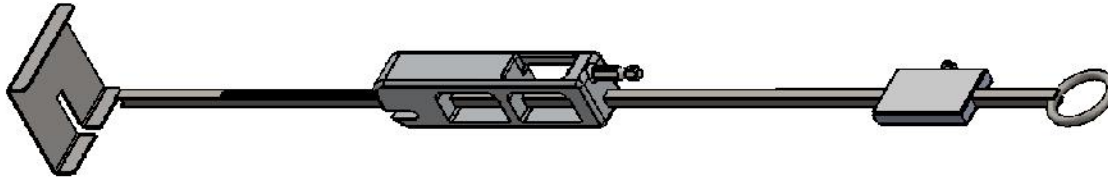

LATCH FORCE TOOL WITH DEPTH SHIELD
SHEET 3-4, 9



WAGNER INSTRUMENTS FDX100
WWW.WAGNERINSTRUMENTS.COM
WITH CONNECTOR, SHEET 9

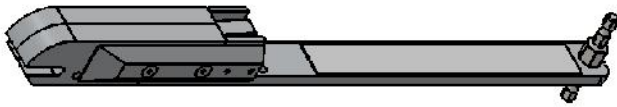

LATCH CLEARANCE ANGLE GAUGE
SHEET 5-9

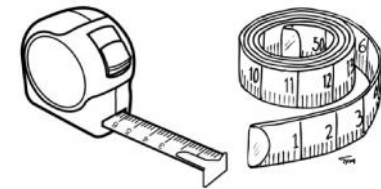

MEASURING TAPE

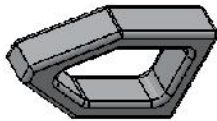

TETHER ROUTING TOOL
SHEET 10



PROBE THERMOMETER



WIXEY WR365 ANGLE GAUGE
WWW.WIXEY.COM



CASE SUCH AS PLANO 108361
36" GUN CASE

UNLESS OTHERWISE SPECIFIED:	DRAWN	NAME	DATE
	CHECKED	R Jones	6/12/15
DIMENSIONS ARE IN MM TOLERANCE:	COMMENTS:		
MATERIAL	VARIED		
FINISH			
DO NOT SCALE DRAWING			

Insurance Institute for Highway Safety
988 Dairy Rd, Ruckersville, VA 22968 (434)985-4600

LATCH TOOL KIT

SCALE: NONE WEIGHT: VARIES SHEET 2 OF 10

REVISIONS			
REV.	DESCRIPTION	DATE	BY
A	CORRECT DATUM FOR DEPTH DIMENSION TO MATCH SLIDER DIMENSION. ADD FITS FOR ROD SIZE. ADD DEPTH SHIELD ACTUAL THICKNESS. CAHNGE IHS LOGO. CHANGE ROD DATUM TO EDGE OF ARC. ADD INCLINOMETER STAGE.	2/1/2017	RGJ

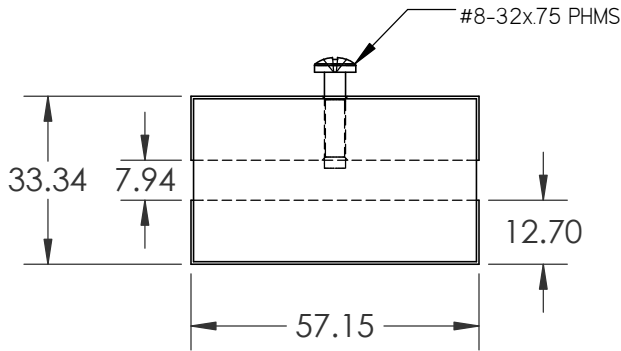

INCLINOMETER STAGE
18ga POWDERCOATED STEEL GLUED TO 1/4"X1/2" ALUMINUM

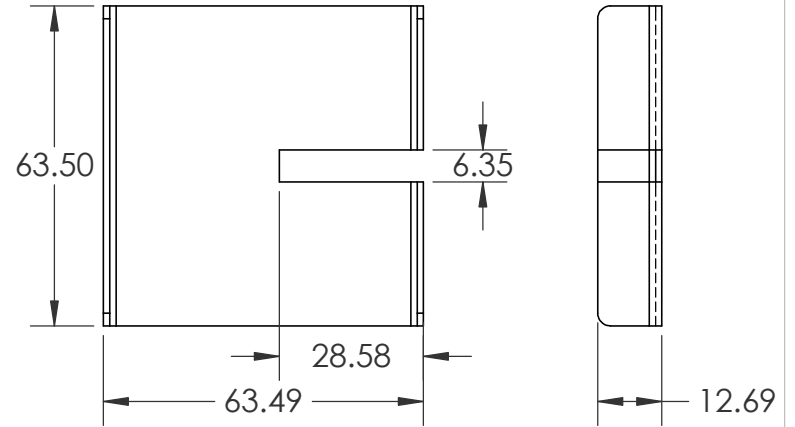
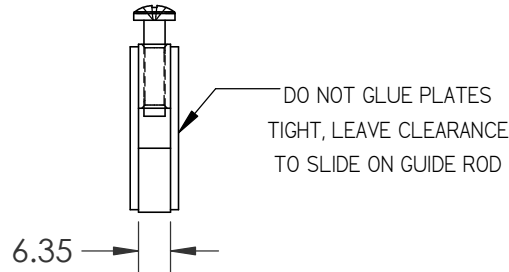

DEPTH SHIELD 18 ga. (1.47MM) 304SS

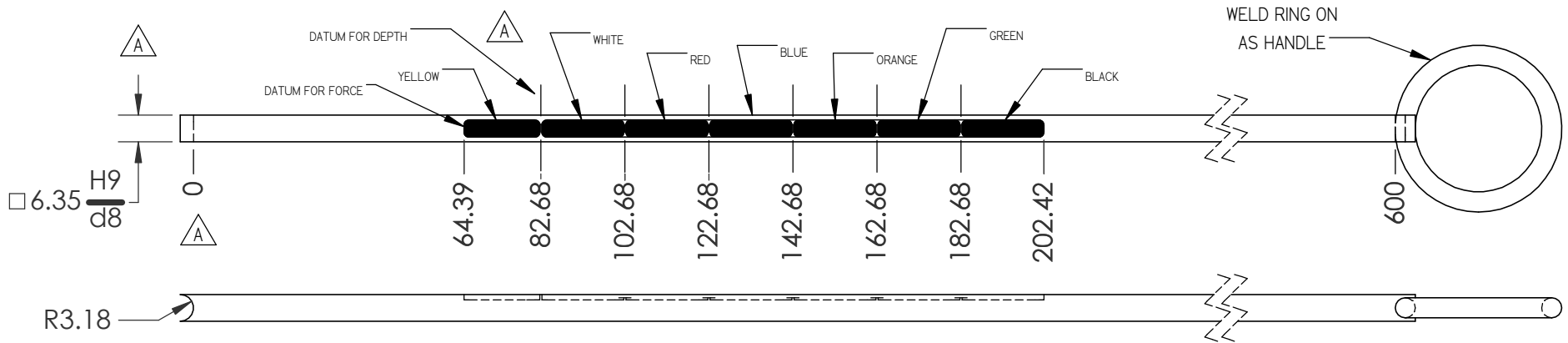

GUIDE ROD 4140 ALLOY

UNLESS OTHERWISE SPECIFIED:	NAME	DATE
DIMENSIONS ARE IN MM TOLERANCE: ±0.1	R Jones	3/18/2015
MATERIAL VARIOUS	COMMENTS: BREAK EDGES	
FINISH AS MILLED		
DO NOT SCALE DRAWING		

Insurance Institute for Highway Safety
988 Dairy Rd, Ruckersville, VA 22968 (434) 985-4600

GUIDE ROD, INCLINOMETER STAGE & DEPTH SHIELD

SCALE: 2:3 WEIGHT: VARIED SHEET 3 OF 10

REVISIONS			
REV.	DESCRIPTION	DATE	BY
A	ADD FITS TO SQUARE HOLE. ADD WEIGHT TOL. CHANGE IIHS LOGO. ADD F GAUGE ADAPTER. ADD SPOTFACE.	2/1/2017	RGJ

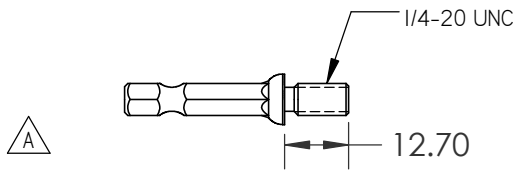

FORCE GAUGE ADAPTER

MACHINED FROM POWER
DRIVER ADAPTER SUCH AS DEWALT DWA2509-6IR
SEE SHEET 9 OF 10

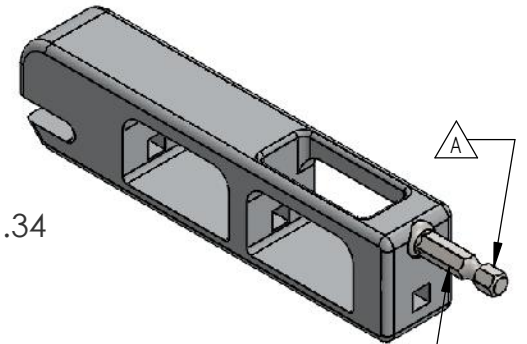
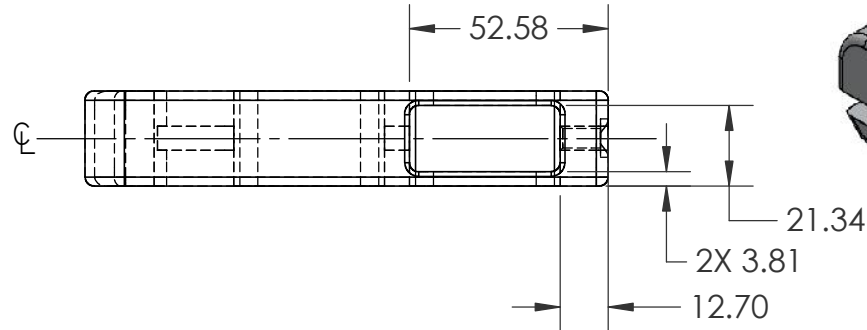

MACHINE SPOTFACE AND/OR CHEMICAL THREADLOCKER
TO ALIGN CONNECTOR SUCH THAT, WHEN ATTACHED,
FORCE GAUGE READS FROM TOP.

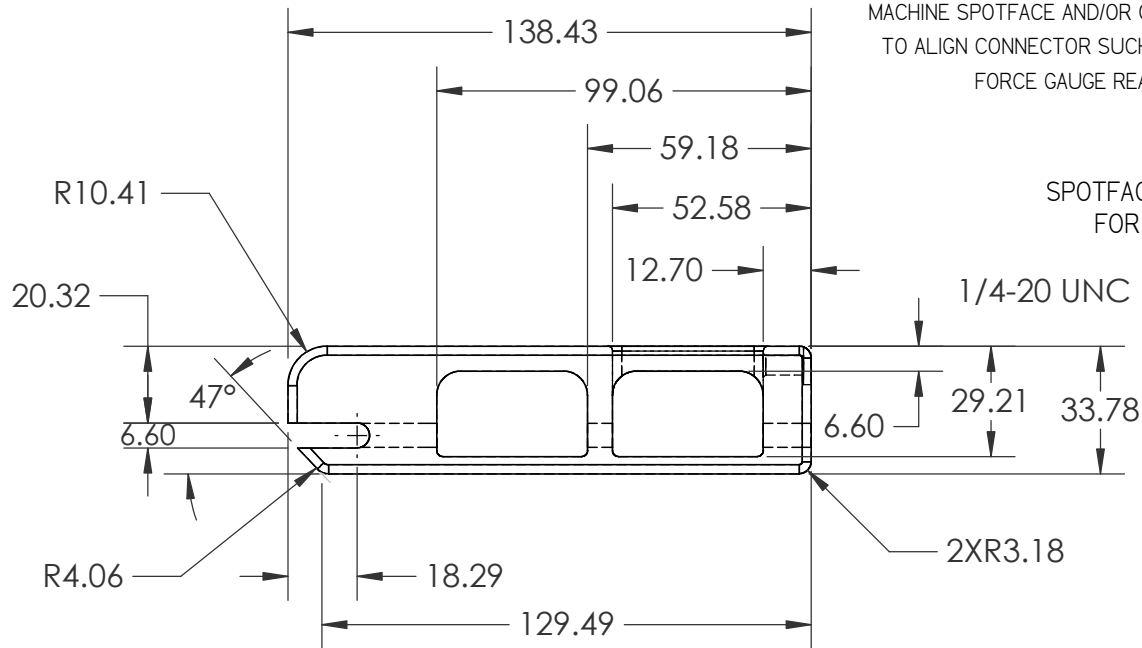
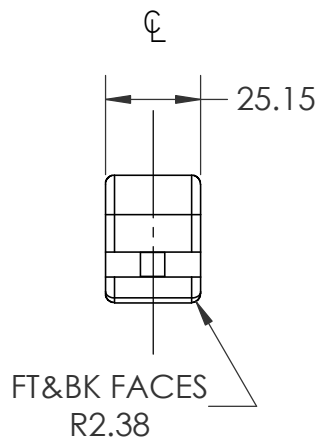

SPOTFACE AS NEEDED
FOR ADAPTER

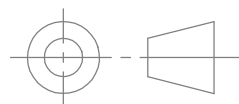
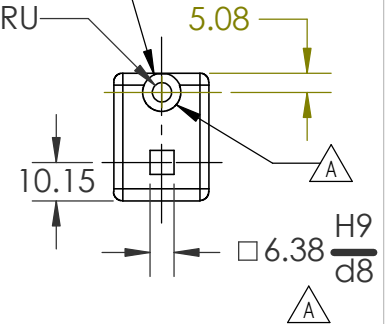

UNLESS OTHERWISE SPECIFIED:

DIMENSIONS ARE IN MM
TOLERANCE: ±0.1

MATERIAL
6061-T6 ALUMINUM ALLOY

FINISH
AS MILLED

DO NOT SCALE DRAWING

	NAME	DATE
DRAWN	R Jones	3/18/2015
CHECKED		
COMMENTS:		

Insurance Institute for Highway Safety
988 Dairy Rd, Ruckersville, VA 22968 (434) 985-4600

LATCH F TOOL SLIDER WITH ADAPTER

SCALE: 1:2 WEIGHT: 174g ±5% SHEET 4 OF 10

REVISIONS			
REV.	DESCRIPTION	DATE	BY
A	CHANGE TO ARM ASM W/ 1/4-20 HOLE AND INCLINOMETER BASE. ADD WT TOLERANCE. ADD GAUGE ADPTRS. REMOVE U BOLT. CHANGE IIHS LOGO.	2/1/2017	RGJ

#	DESCRIPTION (MCMMASTER CARR#)	QTY	SHT # (of 10)
1	Clr Ga Left Side	1	6
2	Catch Lever	1	8
3	Clr Ga Right Side	1	6
4	Scale	2	7
5	Insert	2	7
6	FHCS 6-32x3/8" (90585A212)	4	
7	FHCS 8-32x1/2" (90585A228)	8	
8	3/16"x1" Dowel Pin (97395A473)	1	
9	3/16"x1/2" Dowel Pin (97395A461)	1	
10	Flanged Poly Bearing 3/16"x1/4" (6627K11)	2	
11	FHCS 1/4-20x1" (90585A542)	1	
12	5/8"L Conical Spring (1692k22)	1	
13	Conn Plug Clr Gge, Female	1	9
14	Conn Plug Clr Gge, Male	1	9
15	Arm Assembly	1	8

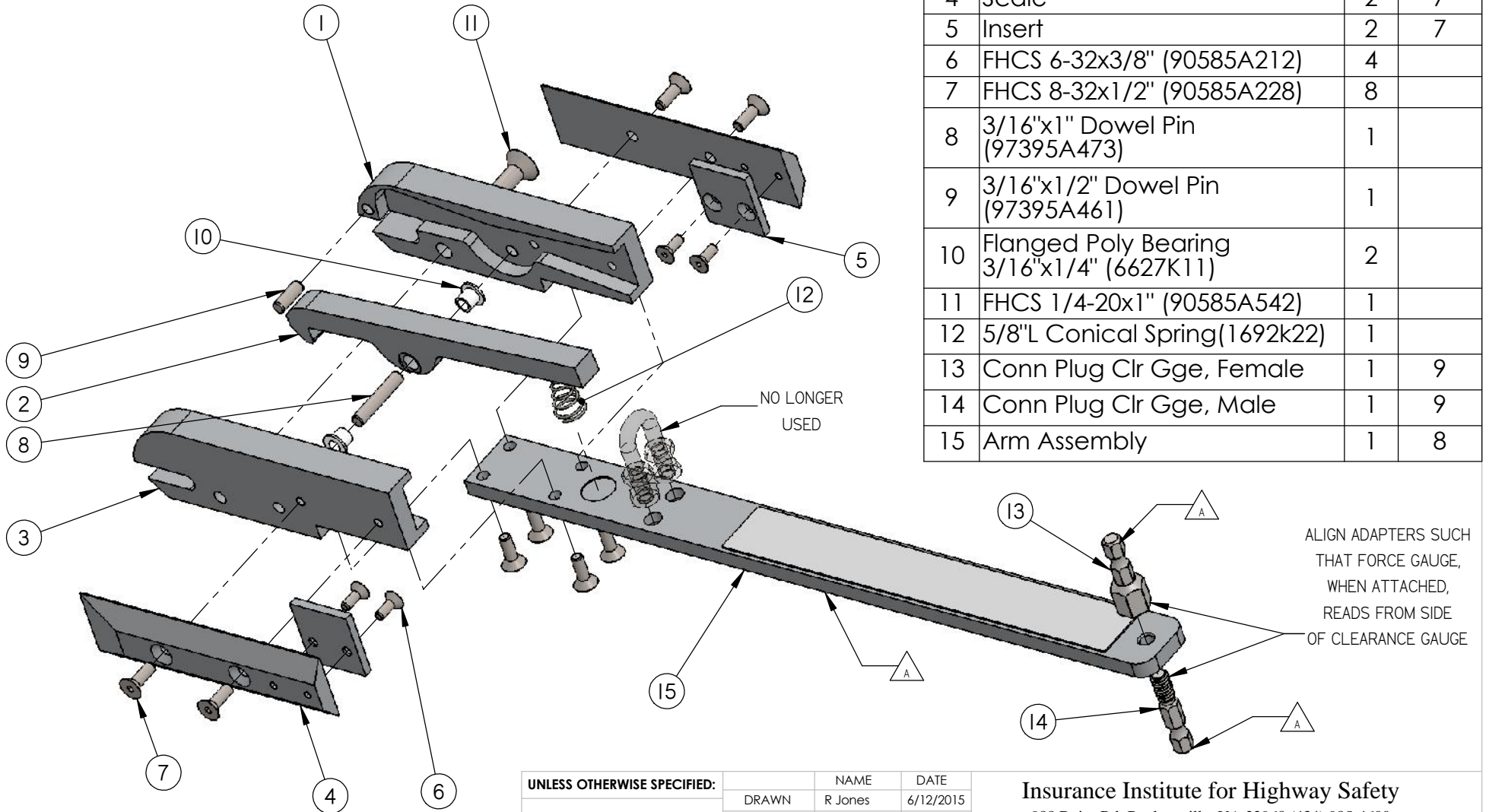

UNLESS OTHERWISE SPECIFIED:	DRAWN	NAME	DATE
	CHECKED	R Jones	6/12/2015
DIMENSIONS ARE IN MM TOLERANCE: ±0.1			
MATERIAL VARIED			
FINISH AS MACHINED			
DO NOT SCALE DRAWING			
COMMENTS:			

Insurance Institute for Highway Safety
988 Dairy Rd, Ruckersville, VA 22968 (434) 985-4600

CLEARANCE GAUGE ASSEMBLY

SCALE: 1:2 WEIGHT: 432g ±5% SHEET 5 OF 10

REVISIONS			
REV.	DESCRIPTION	DATE	BY
A	CHANGE IHS LOGO.	2/1/2017	RGJ

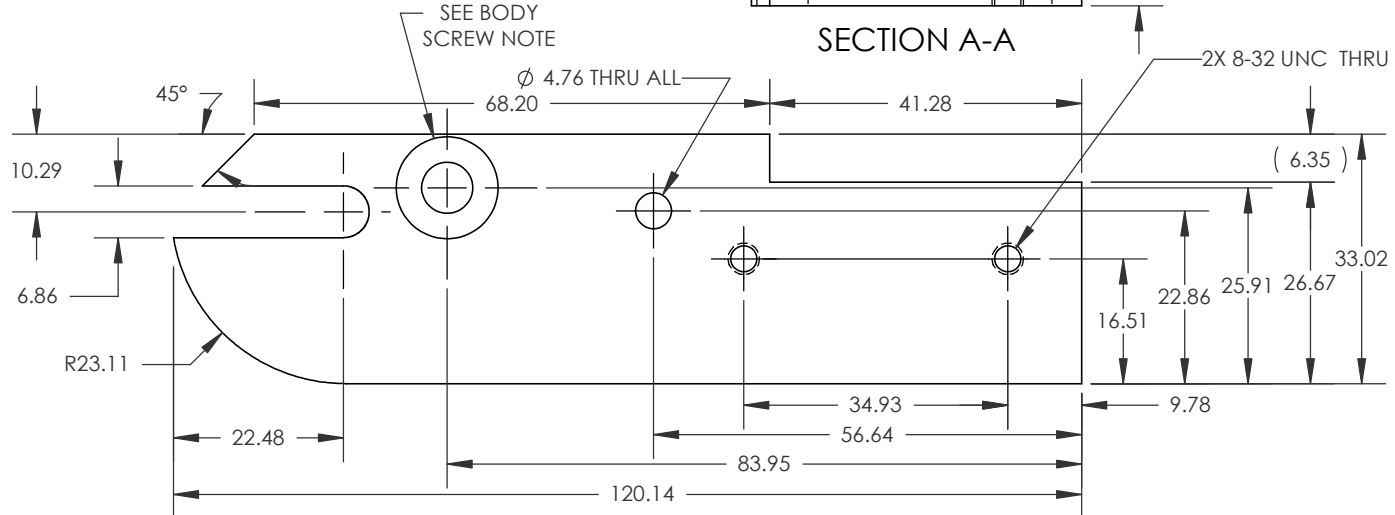
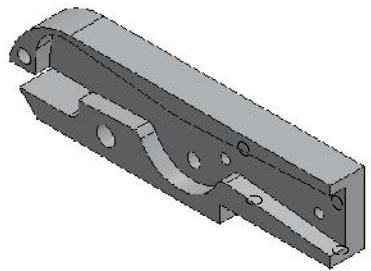
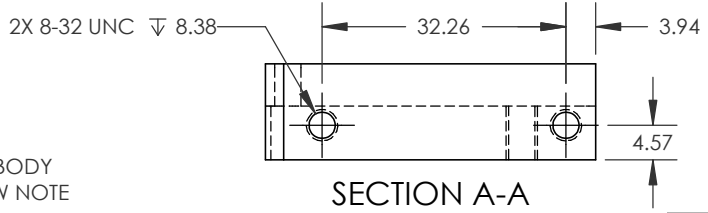
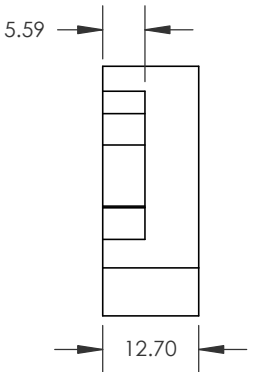
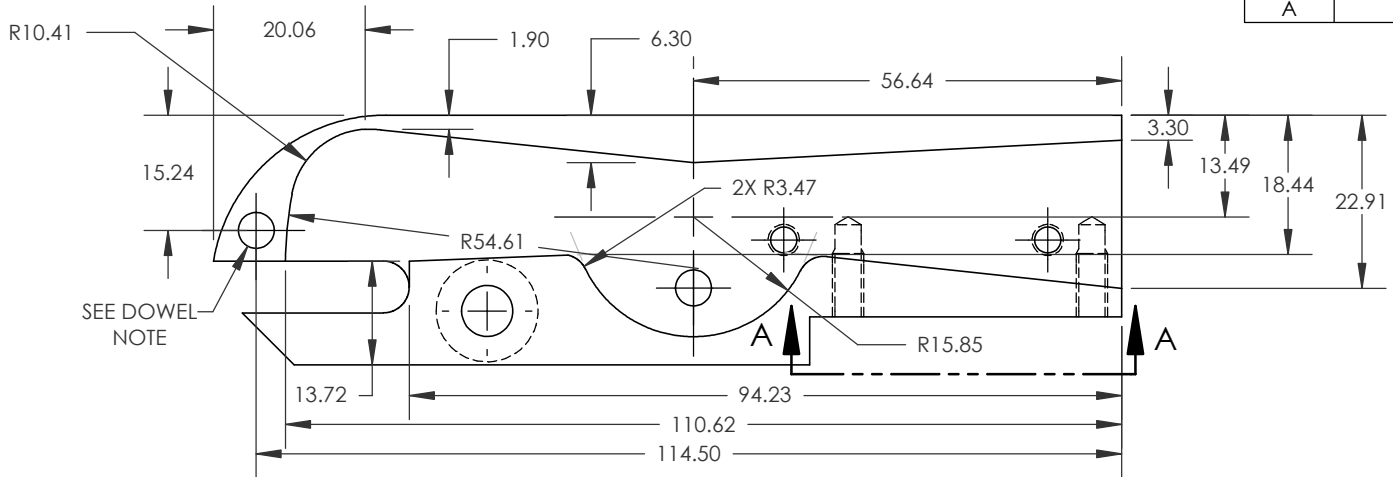

LEFT SIDE DRAWN, RIGHT SIDE OPP HAND EXCEPT:

DOWEL NOTE: LEFT: $\varnothing 4.75 \nabla 9.65$ RIGHT: $\varnothing 4.79 \nabla 9.65$

BODY SCREW: LEFT: $\varnothing 6.76$ THRU ALL $\sphericalangle \varnothing 13.49 \times 82^\circ$
 RIGHT: 1/4-20 UNC THRU ALL

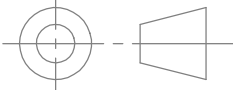

UNLESS OTHERWISE SPECIFIED:

**DIMENSIONS ARE IN MM
TOLERANCE: ± 0.1**

MATERIAL: **6061-T6 ALLOY**

FINISH: **AS MACHINED**

DO NOT SCALE DRAWING

	NAME	DATE
DRAWN	R Jones	6/5/2015
CHECKED		

COMMENTS:
BREAK ALL EDGES

Insurance Institute for Highway Safety
 988 Dairy Rd, Ruckersville, VA 22968 (434) 985-4600

**CLEARANCE GAUGE
 BODY, L & R SIDES**

SCALE: 1:1	WEIGHT: 84g	SHEET 6 OF 10
------------	-------------	---------------

REVISIONS			
REV.	DESCRIPTION	DATE	BY
A	CHANGE IIHS LOGO	2/1/2017	RGJ

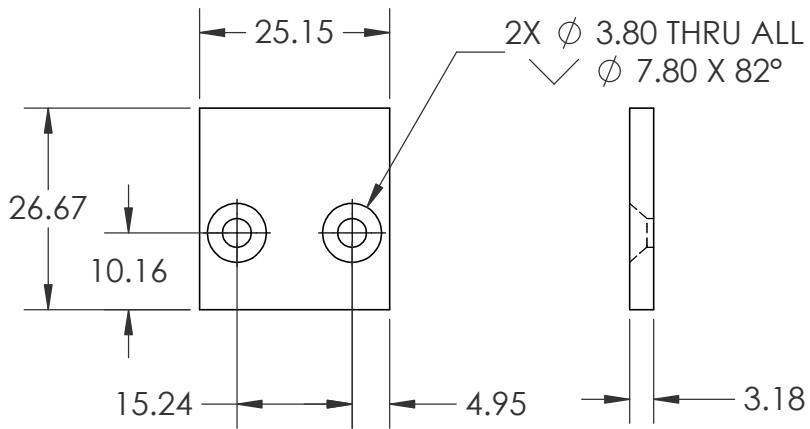
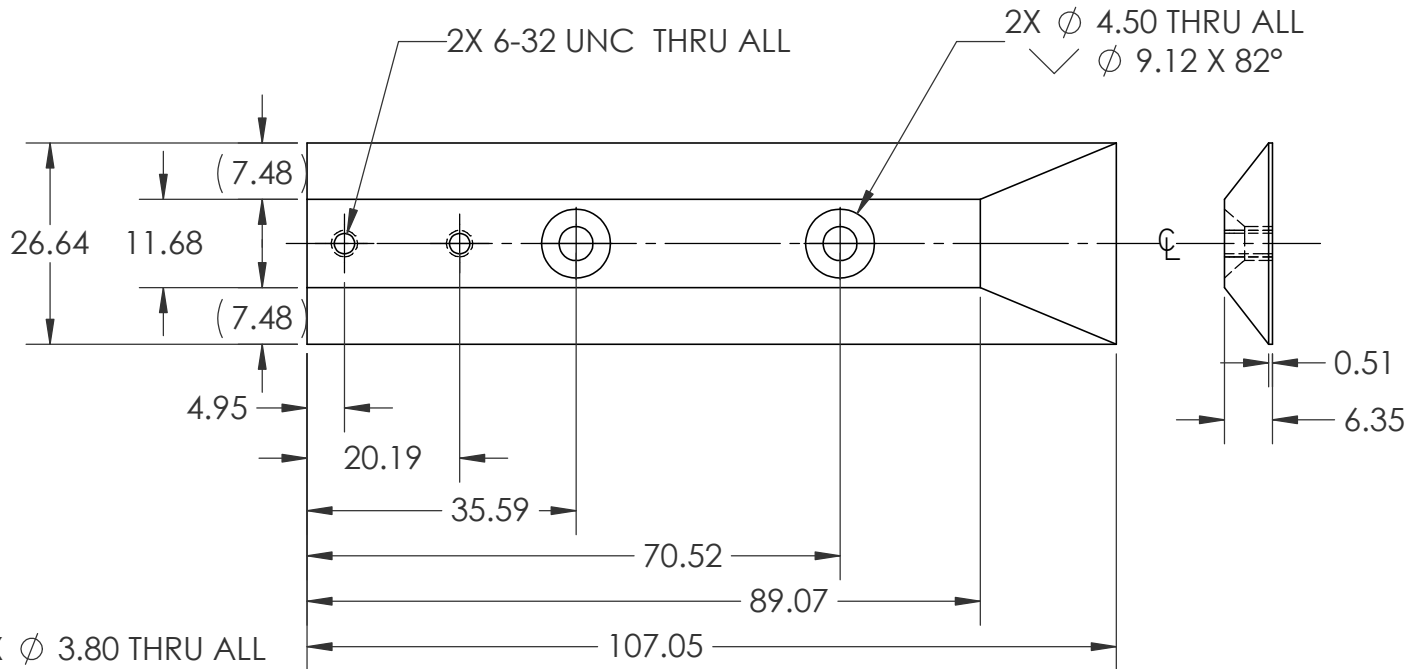

SCALE

INSERT

UNLESS OTHERWISE SPECIFIED:

DIMENSIONS ARE IN MM
TOLERANCE: ±0.1

MATERIAL
6061-T6 ALLOY

FINISH
AS MACHINED

DO NOT SCALE DRAWING

	NAME	DATE
DRAWN	R Jones	6/11/2015
CHECKED		
COMMENTS:		

Insurance Institute for Highway Safety
988 Dairy Rd, Ruckersville, VA 22968 (434) 985-4600

SCALE AND INSERT

SCALE: 1:1 WEIGHT: VARIED SHEET 7 OF 10

REVISIONS			
REV.	DESCRIPTION	DATE	BY
A	ADD INCLINOMETER ATTACH PLATE. 1/4-20 HOLE FOR ADAPTER. CHANGE IHS LOGO.	2/1/2017	RGJ

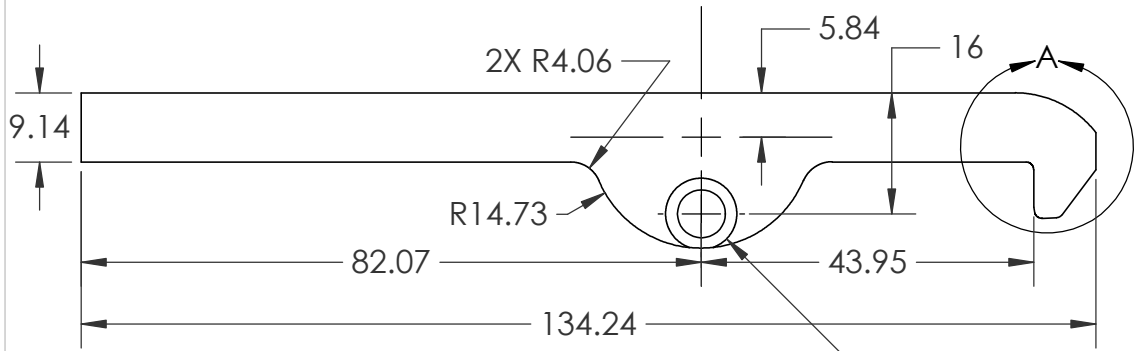

ϕ 6.35 THRU ALL
 2X \square ϕ 9.53 ∇ TO SIDE CLEARANCE FOR FLANGED BEARING

CATCH LEVER
SCALE 1:1

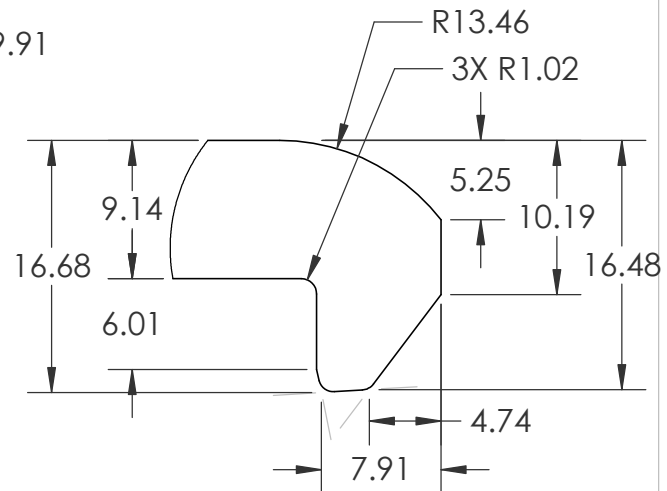
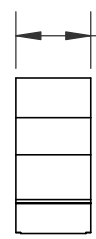

DETAIL A
SCALE 2:1

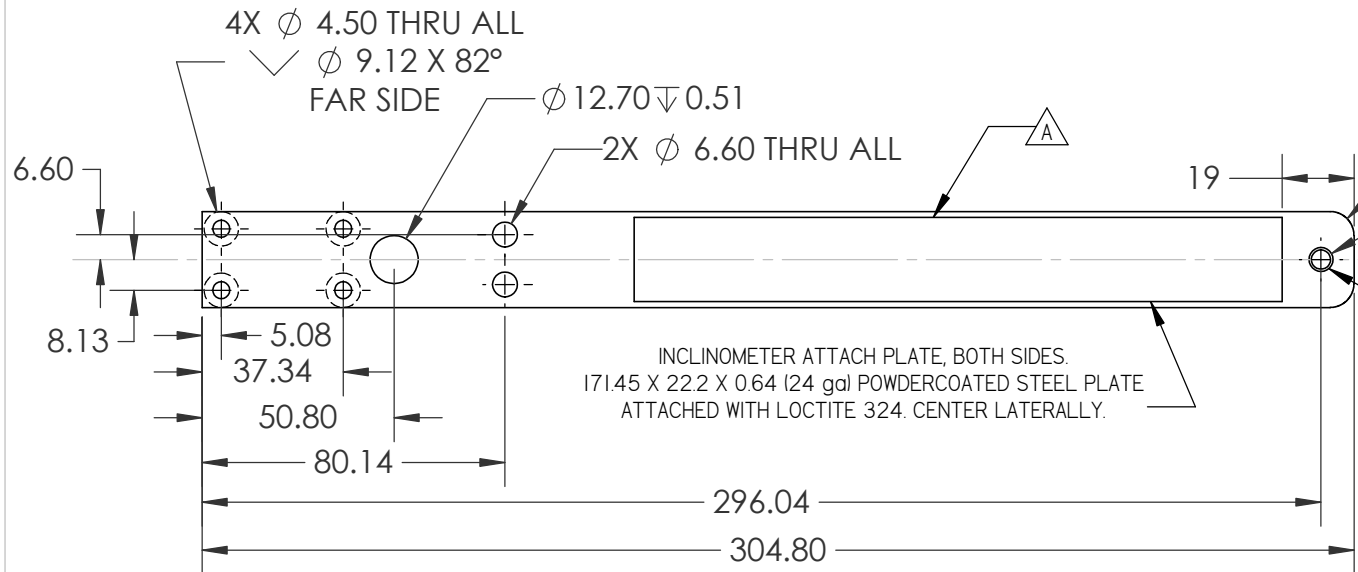

INCLINOMETER ATTACH PLATE, BOTH SIDES.
 171.45 X 22.2 X 0.64 (24 gal) POWDERCOATED STEEL PLATE
 ATTACHED WITH LOCTITE 324. CENTER Laterally.

ARM
SCALE 1:2

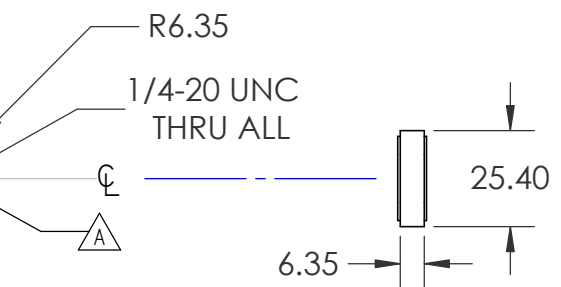
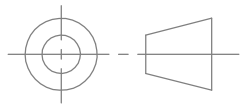

UNLESS OTHERWISE SPECIFIED: DIMENSIONS ARE IN MM TOLERANCE: ± 0.1 MATERIAL 6061-T6 ALLOY FINISH AS MACHINED DO NOT SCALE DRAWING	DRAWN	NAME	DATE
	CHECKED	R Jones	6/11/2015
	COMMENTS:		

Insurance Institute for Highway Safety
 988 Dairy Rd, Ruckersville, VA 22968

LEVER AND ARM

SCALE: VARIED | WEIGHT: VARIED | SHEET 8 OF 10

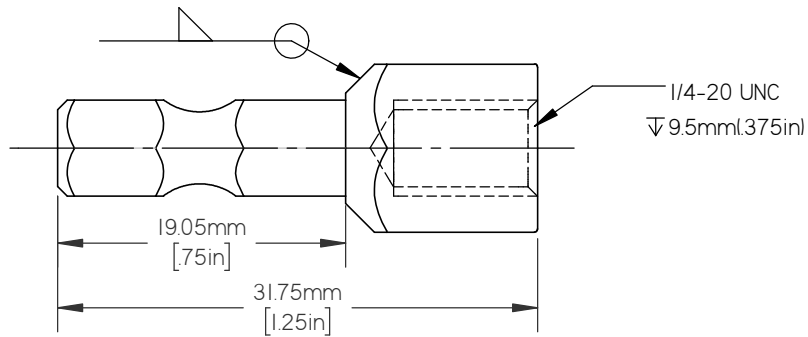

**CONNECTOR PLUG, CLEARANCE GAUGE,
FEMALE THREAD**
FAB FROM DRIVER BIT SHANK AND COUPLING NUT

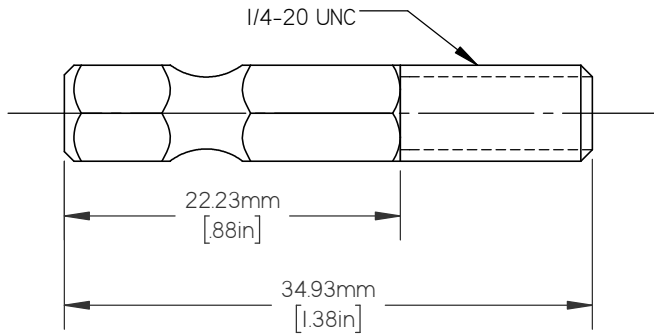

**CONNECTOR PLUG, CLEARANCE GAUGE,
MALE THREAD**
FAB FROM DRIVER BIT SHANK

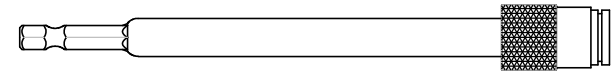

QUICK RELEASE DRIVER BIT EXTENSION,
SUCH AS DEWALT DWA2509-6IR
MAGNETIC COLLAR REMOVED
SCALE 1:2

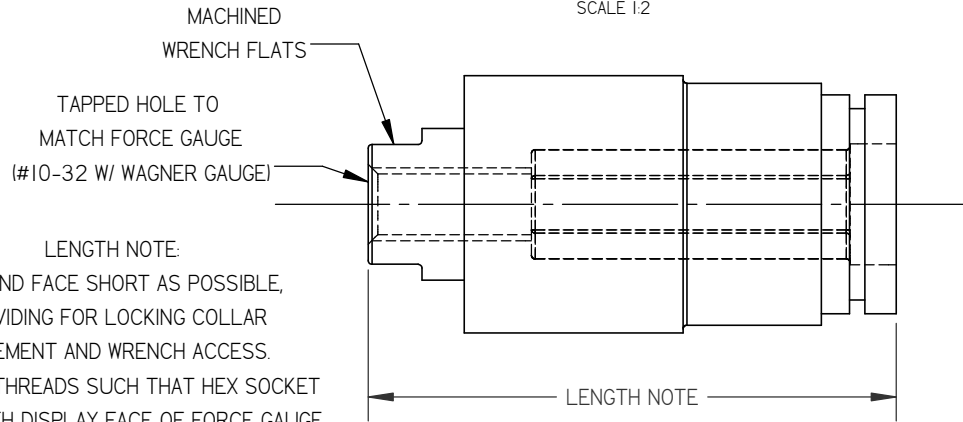

LENGTH NOTE:
CUT AND FACE SHORT AS POSSIBLE,
PROVIDING FOR LOCKING COLLAR
MOVEMENT AND WRENCH ACCESS.
SHORTEN THREADS SUCH THAT HEX SOCKET
ALIGN WITH DISPLAY FACE OF FORCE GAUGE.

CONNECTOR SOCKET, FORCE GAUGE
FAB FROM DRIVER BIT EXTENSION

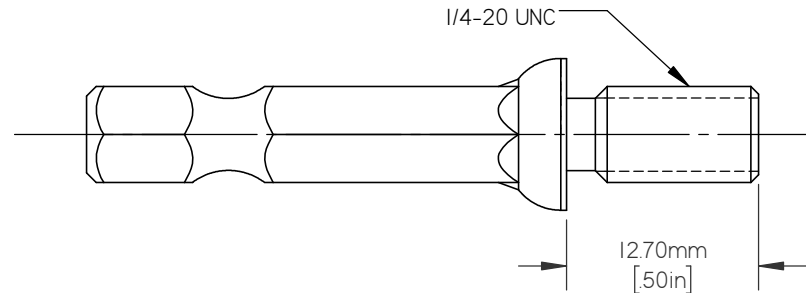

CONNECTOR PLUG, FORCE TOOL
FAB FROM HEX SHANK DEVICE WITH
INCREASED DIAMETER SHANK

UNLESS OTHERWISE SPECIFIED: DIMENSIONS ARE IN MM[IN] TOLERANCE: ±5[.25] MATERIAL VARIED STEEL FINISH COLD BLACKENING DO NOT SCALE DRAWING	DRAWN	NAME	DATE	Insurance Institute for Highway Safety 988 Dairy Rd, Ruckersville, VA 22968 (434) 985-4600 <h1>Gauge Adapters</h1> SCALE: 2:1 WEIGHT: VARIES SHEET 9 OF 10
	CHECKED	R Jones	2/1/2017	
	COMMENTS:			

REVISIONS			
REV.	DESCRIPTION	DATE	BY
A	CHANGE IIHS LOGO	2/1/2017	RGJ

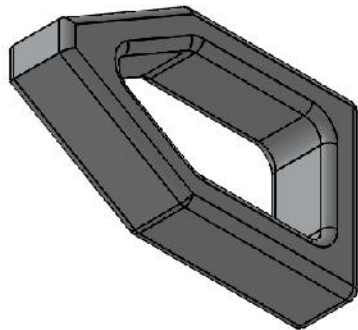
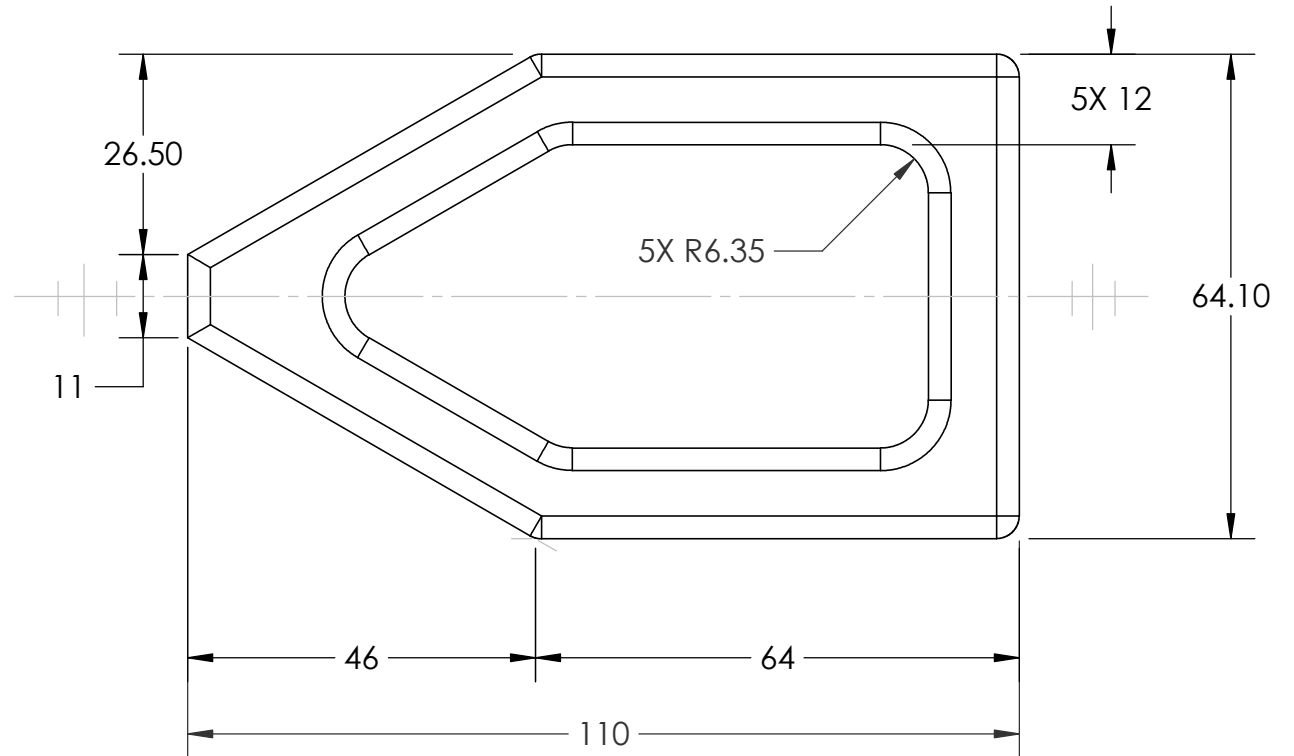
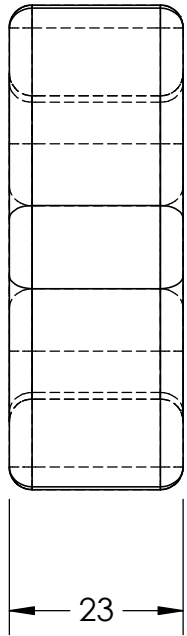

ALL FILLET RADII 3mm

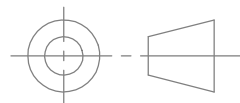

UNLESS OTHERWISE SPECIFIED: DIMENSIONS ARE IN MM TOLERANCE: ± 0.1 MATERIAL 6061-T6 ALUMINUM ALLOY FINISH AS MILLED DO NOT SCALE DRAWING	DRAWN	NAME	DATE	Insurance Institute for Highway Safety 988 Dairy Rd, Ruckersville, VA 22968 (434) 985-4600
	CHECKED	R Jones	5/04/2015	
	COMMENTS:			TETHER ROUTING TOOL
	SCALE: 1:1	WEIGHT: 195 g	SHEET 10 of 10	